

OTTAWA

Ottawa Terminal Tractors... Maintenance Manual

 **KALMAR** OTTAWA



A. Foreword	1
About this manual	1
B. Safety	3
Hazardous condition signs	3
Do's and Dont's	4
C. Preventive maintenance	5
Lubrication Points	5
Lubrication Points	5
Inspections	6
Every Day	6
Every 250 Hours of Operation	6
Every 500 Hours of Operation	6
Every 1,000 Hours of Operation	6
Every 2,000 Hours of Operation	6
Checklists	7
Daily Inspection Checklist	7
Preventive Maintenance Forms	9
Preventive Maintenance Technique	11
General	11
Fuel, Filters, Fluids and Lubricants	11
Maintenance	11
Cab Interior	12
Maintenance	12
Cab Down — Exterior	13
Maintenance	13
Cab Up	14
Maintenance	14
Under Vehicle	16
Maintenance	16
Chassis	17
Maintenance	17
Lubrication	18
Maintenance	18
Test Drive	19
Maintenance	19
0. Machine Complete	21
The Ottawa Terminal Tractor	21
Description	21
Diesel Fuel Requirements	22
Precautions	22
Emergency Starting	23
Precautions	23
Jump Starting Instructions	23
Vehicle Towing	25
Precautions	25
Front End Towing (Front Wheels Off the Ground)	25
Front End Towing (All Wheels On the Ground)	26
Rear End Towing	26
Vehicle Modifications	27
Approval	27
Vehicle Identification	28
Identification Plate	28
Certification Label	28
Vehicle Serial Number	29
Engine Serial Number	29

Component Location	30
Chassis/Cab, Left Side	30
Ottawa Series, Left Side (4x2 chassis shown)	30
Chassis/Cab, Right Side	31
Ottawa Series, Right Side (4x2 chassis shown)	31
Chassis/Cab, Front/Rear	32
Ottawa Series, Front/Rear (4x2 chassis shown)	32
Chassis, Plan View	33
Ottawa Series, Plan View (4x2 chassis shown)	33
Electrical Instruments	34
Guide to Troubleshooting	34
Basic Gauge Diagnostic Procedure	34
Engine	37
Description	37
Controls and instruments	38
Oil Gauge	38
Diagnosis	38
Fuel Gauge	38
Diagnosis	38
Coolant Gauge	39
Diagnosis	39
Fuel System	40
Fuel tank	40
Description	40
Sensor, fuel level	40
Description	40
Pipes and hoses	40
Description	40
Start / stop	41
Diagnosis (Starting and Charging Diagnosis)	41
Transmission	43
Description	43
Driveline / Axle	45
Description	45
Brakes	47
Controls and instruments	47
Foot Pedal (Treadle Valve)	47
Description	47
Air Control Valves	47
Description	47
Brake System	48
Description	48
Air Compressor and Governor	49
Description	49
Air Reservoir	49
Description	49
Stop Light Switch	50
Description	50
Brakes	50
Description	50
Trailer Brake Air Lines	51
Description	51
Anti-lock Brake System (Optional)	51
Description	51
Automatic Traction Control (Optional)	52

Description	52
Manually Releasing Tractor Spring Brakes (Caging)	52
Description	52
Diagnosis (Mechanical)	55
Brakes	55
Steering	59
Servo steering system	59
Description (Power Steering Components)	59
Description (Optional Hydrostatic Steering Components)	59
Diagnosis Power Steering)	61
Power Steering	61
Diagnosis (Hydrostatic steering)	62
Hydrostatic Steering	62
Suspension	63
Description (Vehicle suspension including Otto-ride)	63
Front Springs and Pins	65
Repair (Springs and Pins Removal)	65
Repair (Springs and Pins Installation)	66
Load Handling	67
Lift and lower	67
Description (Boom Components)	67
Hydraulic pump	67
Description	67
Control Valve	67
Description	67
Boom lift cylinders	68
Description	68
Diagnosis (Boom)	69
Diagnosis	69
Control System	71
Introduction - General Information	71
Frame, body, cab and accessories	73
Controls and Instruments	73
Description	73
Low Air Warning	75
Diagnosis	75
Ammeter	75
Diagnosis	75
Hourmeter	76
Diagnosis	76
Speedometer	77
Diagnosis	77
Tachometer	78
Diagnosis	78
Voltmeter	79
Diagnosis	79
Seating	80
Description	80
Heating, ventilation and air conditioning	81
Description	81
Wiping and cleaning of windows	82
Windshield Wipers	82
Description	82
Diagnosis	82
Windshield Washer	83

Description	83
Diagnosis	83
Lighting system	84
Description	84
Headlights	84
Diagnosis	84
Clearance, Marker and Tail Lights	85
Diagnosis	85
Brake Lights	86
Diagnosis	86
Backup Light	87
Diagnosis	87
Turn Signal	88
Diagnosis	88
Beacon Light	89
Diagnosis	89
Dome Light	89
Diagnosis	89
Daytime Running Lights	90
Diagnosis	90
Trailer Auxiliary Power	90
Diagnosis	90
Transmission Shifter/Fifth-Wheel Control and Panel Lighting	91
Diagnosis	91
Signal system	92
Horn	92
Diagnosis	92
Emergency Flasher	92
Diagnosis	92
Backup Alarm	93
Diagnosis	93
Maintenance and communication	94
Radio	94
Description	94
Diagnosis	94
Glass / window / mirrors	95
Description	95
Rear-view mirror	95
Description	95
Construction and Suspension of Cab/Deck	96
Cab frame	96
Description	96
Doors	97
Description	97
Repair (Rear Door Adjustment)	97
Cab Tilting	98
Description	98
Cab Tilt (hydraulic) Components	100
Diagnosis (Cab Tilt)	101
Roof and door mouldings	102
Description	102
Cab Tilt Cylinder	103
Repair (Cylinder Removal)	103
Repair (Cylinder Installation)	104
Cab Mounting and Suspension	105

Description	105
Diagnosis (Cab Air Suspension)	105
Air Ride Suspension (Three-Point)	106
Repair (Cab Suspension Assembly Removal)	106
Repair (Cab Suspension Assembly Installation)	106
Repair (Air Ride Level Adjustment)	107
Leveling Valve	108
Repair (Valve Operation Check)	108
Shock Absorbers	108
Repair (Shock Removal)	108
Repair (Shock Installation)	109
Cab Latch Bar Plate	109
Repair (Latch Bar Plate Adjustment)	109
Cab Tilt Pump and Motor	110
Diagnosis (cab tilt pump)	110
Repair (Pump and Motor Removal)	110
Repair (Pump and Motor Installation)	111
Repair (Relief Pressure Adjustment (2001 and Newer Trucks))	112
Cab Pivot Bushing	112
Repair (Pivot Bushing Removal)	112
Repair (Pivot Bushing Installation)	114
Chassis	115
Description	115
Diagnosis (Chassis)	116
Repair (Frame Damage Analysis)	119
Repair (Making Reinforcements, General Information)	119
Repair (Making Reinforcements, Attachment)	120
Repair (Cracks in Steel Rails or Cross Members)	120
Bodywork	122
Footstep	122
Description	122
Accessories and options	123
Accessory Relay	123
Diagnosis	123
Heater/Air Conditioning (Optional)	123
Diagnosis	123
Mirrors (Heated/Motorized)	124
Diagnosis	124
Common Hydraulics	127
System Description	127
Tanks and accumulators	127
Reservoir	127
Description	127
Temperature control, cleaning and hydraulic oil	128
Return filter	128
Description	128
Common Electric	129
Controls and instruments	129
Description (wiring harness)	129
Safety	130
Fuses, relays and circuit breakers	130
Description	130
Common pneumatics	131
Air System and Brakes	131
Description	131

Diagnosis	131
Brakes — Air System	131
Valves	136
Tractor Protection Valves	136
Proportioning Relay (Bobtail) Valve (Optional)	136
Quick Release Valves	136
Anti-Compounding Valve (Optional)	136
Double (Two-Way) check Valves	136
Air Dryer	137
Description	137
Diagnosis	137
D. Error Codes	139
Description	139
E. Schematics	141
Air System Circuits	141
Air Brakes	141
Components	141
Air Brake System with Split Brakes	142
Air Brake System without ABS	143
Cab Seating	144
Air Lines — Driver's Seat	144
Cab Suspension	145
Air Lines — Cab Suspension	145
Fifth-Wheel Coupling	146
Air Lines — Fifth-Wheel Latch	146
Hydraulic System Circuits	147
Hydraulic Systems	147
Cab Tilt	147
Hydraulic Lines — Cab Tilt	147
Fifth-Wheel Boom	148
Hydraulic Lines — Fifth-Wheel Boom	148
Power Steering	149
Hydraulic Lines — Power Steering	149
Optional Hydrostatic Steering	150
Hydraulic Lines — Hydrostatic Steering	150
Electrical System Circuits	151
Starting and Charging	151
Starting and Charging Circuit	151
Cab Accessory Components	152
Wire Color Codes	152
Anti-lock Braking System (ABS)	153
Heater and Air Conditioning	153
Horn	154
Mirrors	155
Radio (Optional)	157
Windshield Washer (Optional)	159
Windshield Wiper	160
Cab Instrumentation	161
Air Pressure Gauge Lighting	161
Ammeter (Optional)	162
Engine Coolant Temperature Gauge	163
Engine Hourmeter	164
Engine Oil Pressure Gauge	165
Fuel Gauge	167
Low Air Warning Alarm	168

Speedometer (Optional)	169
Tachometer (Optional)	170
Transmission Oil Temperature Gauge	171
Voltmeter	173
Chassis Circuits	174
Air Dryer (Optional)	174
Cab Tilt Pump	175
Lighting Circuits (Cab and Chassis)	176
Backup Light and Alarm	176
Beacon/Strobe Light	177
Clearance Lights	178
Daytime Running Lights (Optional)	179
Dome Light	180
Fifth-Wheel Control	181
Flood Light	181
Headlights	182
Marker Lights	182
Panel Lighting	182
Strobe Light	182
Tail Lights	182
Trailer Auxiliary Power	183
Transmission Shifter, Fifth-Wheel Control and Panel Lighting	184
Turn Signal, Tail, Brake Lights and Emergency Flasher	185
F. Technical Data	189
Standard Vehicle Data	189
Ottawa Series Terminal Tractor	189
Hydraulic System	191
Ottawa Series 4x2 and 6x4	191
Fluids, Lubricants and Sealants	192
Ottawa Series 4x2 and 6x4	192
Fastener Torque Values	194
Ottawa Series 4x2 and 6x4	194
G. Appendixes	195
Description	195

– A. Foreword

About this manual

This service manual covers the Ottawa 4x2 and 6x4 terminal (yard) tractors produced by Cargotec Solutions LLC, Kalmar Terminal Tractors. You will find here descriptions of the features, location and operation of the components. Diagnostic and repair procedures are included along with schematic diagrams of the electric, pneumatic and hydraulic circuits. There is a table of specifications and a schedule for preventive maintenance.

Basic information, diagnostic and repair procedures are provided for the uniquely Ottawa features and components. Designed to provide the owners and operators of Ottawa 4x2 and 6x4 terminal tractors with the information necessary to service and maintain their vehicles properly, this manual presents the information in eight sections.

For the major components, such as engine, transmission and axles, follow the service instructions and guidelines provided by the component manufacturer. This applies also to lesser components, such as the steering gear, ABS controllers and other system components, that are produced by quality manufacturers and supplied to Kalmar for production of Ottawa vehicles.

It is our hope that this manual will help you to realize maximum utility, efficiency, reliability and durability from your Ottawa tractor.

– B. Safety

Hazardous condition signs

The following signs accompanied by an explanation are used to advise the reader of the degree of hazard associated with the procedure being described.

 DANGER

A situation that may result in serious personal injury, possibly death, if the instruction is not followed.
--

 WARNING
--

A situation that may result in serious personal injury if the instruction is not followed.

 CAUTION
--

A situation that may result in damage to the product if the instruction is not followed.

NOTE

Information that is important without being safety related.

Note is used to facilitate the work process, operation/handling or to increase understanding of the information.

Do's and Dont's



WARNING

Always disconnect the batteries before welding on or near the vehicle. Improper welding procedures may damage the alternator or batteries. Failure to heed this warning may result in serious personal injury or property damage.

- Do use care when removing the radiator filler cap. When the engine is hot, rotate the cap to the first detent, allow the pressure to dissipate and then remove it.
- Do stay clear when lowering the cab.
- Do set the parking brake when parking the vehicle.
- Don't apply full throttle while the engine is cold.
- Don't allow sparks or flames near a charging battery.
- Don't allow sparks or flames nearby when inspecting fuel, fuel tank or filler-neck strainer.
- Don't operate a vehicle in an enclosed area without adequate ventilation.
- Don't operate the vehicle with inspection plates, cover plate or engine access doors removed or open.
- Don't weld or flame cut frame rails or drill holes in rail flanges.
- Don't modify the vehicle or its equipment without the advice and written consent of the Engineering department at Kalmar.
- Don't push start the vehicle.
- Don't stand or work under a raised cab unless the safety prop on the tilt cylinder is locked.
- Don't jump start the vehicle using welding equipment.
- Don't operate the vehicle with air pressure below 70 PSI.
- Don't shift the transmission from neutral to drive or reverse at engine speeds above idle.

– C. Preventive maintenance

0.1 Lubrication Points

Lubrication Points

1. Coolant/Antifreeze
2. Engine Oil
3. Slack Adjusters Brake Cam Pivot
4. Front Axle King Pins
5. Tie Rod Ends
6. Transmission Fluid
7. Diesel Fuel
8. Universal Joints
9. Rear Axle Differential
10. Driveline Slip Yoke
11. Hydraulic/Steering Fluid
12. Cab Suspension Latch
13. Spring Shackle Pins
14. Front Wheel Bearings
15. Drag Link Ends
16. Steering Slip Joint

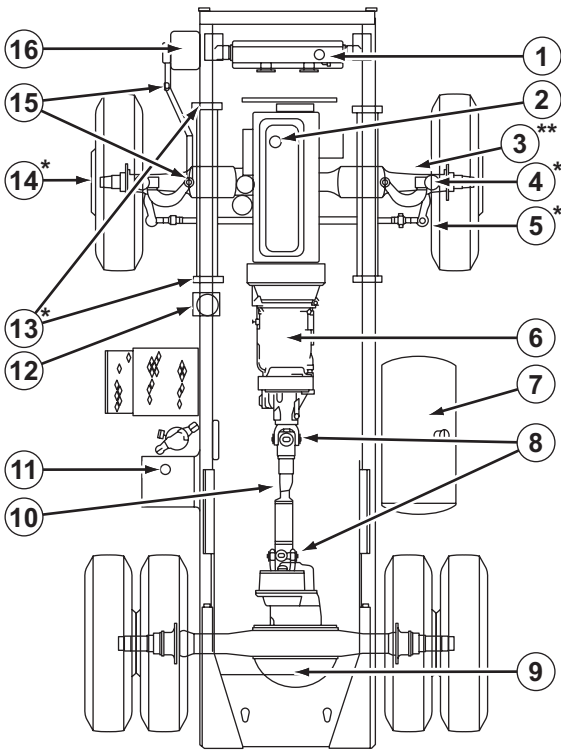

* BOTH SIDES

** BOTH SIDES FRONT AND REAR

OTT0001

Chassis Lubrication Diagram — Left-Hand Drive

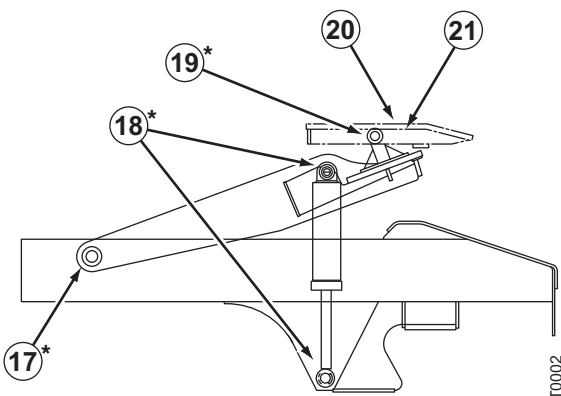

* BOTH SIDES

OTT0002

Boom and Fifth-Wheel Lubrication Diagram

17. Boom Pivot
18. Boom Cylinder Bearings
19. Fifth-Wheel Pivot
20. Fifth-Wheel Top Plate
21. Fifth-Wheel Jaws
- Side Door Hinge (not shown)
- Rear Door Upper Rollers (not shown)

0.2 Inspections

Every Day

Perform the inspections listed in the [Daily Inspection Checklist page 7 and page 8]

At each inspection, add fluids and lubricants as indicated. Repair all leaks. Replace cracked, damaged or worn parts.

Every 250 Hours of Operation

Perform the inspections listed in column **A** of the chart. Refer to the Preventive Maintenance Forms page 9 and page 10.

These service procedures must be performed after every 250 hours of operation or every month, whichever occurs first.

Every 500 Hours of Operation

Perform the inspections listed in column **B** of the chart. Refer to the Preventive Maintenance Forms page 9 and page 10.

These service procedures must be performed after every 500 hours of operation, or every three months, whichever occurs first.

Every 1,000 Hours of Operation

Perform the inspections listed in column **C** of the chart. Refer to the Preventive Maintenance Forms page 9 and page 10.

These service procedures must be performed after every 1,000 hours of operation.

Every 2,000 Hours of Operation

Perform the inspections listed in column **D** of the chart. Refer to the Preventive Maintenance Forms page 9 and page 10.

These service procedures must be performed after every 2,000 hours of operation.

0.3 Checklists

Daily Inspection Checklist

- r Fuel tank
- r Engine oil level (engine stopped)
- r Coolant level
- r Windshield washer fluid level (if applicable)
- r Fuel water separator
- r Transmission fluid level (engine running)
- r Hydraulic fluid level (boom full down)
- r Front wheel hub oil level (if applicable)
- r Engine belt condition and tension
- r Steering system
- r Hoses and wiring
- r Exhaust system
- r Drain air tanks
- r Trailer lines, glad-hand seals and trailer cord
- r Catwalk, boom deck and grab handles
- r Lift cylinders
- r Cab doors and latches
- r Cab hold down latch
- r Fifth-Wheel, secondary lock, jaws and cylinder operation
- r Boom control lever operation
- r Tire condition
- r Oil pressure alarm and gauge operation
- r Transmission shift lever operation
- r Backup alarm operation
- r Windshield wiper and washer operation
- r Horn
- r Radio equipment
- r Gauges and dash lights
- r Dome lights
- r Turn signals
- r Hazard lights
- r Headlights
- r Marker lights
- r Backup lights
- r Brake lights
- r Strobe light (if applicable)
- r Auxiliary backup lights

- r Clean the cab interior.
- r Clean the windows.
- r Clean and adjust the mirrors.

Preventive Maintenance Forms

KALMAR TERMINAL TRACTOR PREVENTATIVE MAINTENANCE FORM 2007 OR NEWER ENGINES NON-SYNTHETIC (TES-295) LUBE USED IN THE TRANSMISSION

TRUCK NUMBER	LOCATION	TECHNICIAN	HOURS	DATE							
EACH OF THE FOLLOWING ITEMS SHOULD BE CHECKED AND THE CORRESPONDING BOX MARKED WITH THE APPROPRIATE NOTATION. √ = SATISFACTORY 0 = ADJUSTMENT NECESSARY X = REPAIRS NEEDED. "A" INSPECTIONS SHOULD BE PERFORMED AT 250 HOUR INTERVALS. "B" INSPECTIONS AT 500 HOUR INTERVALS. "C" INSPECTIONS AT 1000 HOUR INTERVALS, AND "D" INSPECTIONS AT 2000 HOUR INTERVALS. SHADED BOXES INDICATE THAT THE OPERATION SHOULD NOT BE DONE AT THAT INTERVAL.											
OPERATION		A	B	C	D	OPERATION		A	B	C	D
CAB – INTERIOR						UNDER VEHICLE					
CHECK OPERATION OF NEUTRAL START						CHECK STEERING GEAR					
CHECK OPERATION OF ALL GAUGES						CHECK BRAKE LININGS AND DRUMS					
CHECK LOW AIR BUZZER AND LIGHT						CHECK LEAF SPRINGS					
CHECK WINDSHIELD WIPER OPERATION						CHECK SHOCK ABSORBERS (IF APP.)					
CHECK WINDSHIELD WASHER OPERATION (IF APP.)						TORQUE FRONT AXLE MOUNTING BOLTS					
CHECK THROTTLE OPERATION						TORQUE KING PIN DRAW KEY NUT(S)					
CHECK HORN(S) OPERATION						CHECK HYDRAULIC PUMP					
CHECK AIR SYSTEM. MINIMUM 120 PSI, MAXIMUM 130 PSI						CHECK STARTER MOUNTING AND CONNECTIONS					
CHECK AIR SYSTEM FOR LEAK DOWN						CHECK ENGINE AND TRANSMISSION FOR LEAKS					
CHECK OPERATION OF BACK UP ALARM						CHANGE ENGINE OIL AND FILTER					
CHECK HVAC SYSTEM						CHANGE TRANSMISSION FILTERS					
BLOWER MOTOR OPERATION						CHANGE TRANSMISSION FLUID					
TEMPERATURE CONTROL						CHECK ENGINE AND TRANSMISSION MOUNTS					
DEFROSTER OPERATION						CHECK WHEEL SEALS FOR LEAKS					
A/C OPERATION (IF APP.)						CLEAN REAR AXLE BREATHER					
AUXILIARY FAN(S) (IF APP.)						CHECK DIFFERENTIAL FOR LEAKS					
CHECK 5 TH WHEEL UNLATCH CONTROL						CHECK DIFFERENTIAL OIL LEVEL					
CHECK OPERATION OF BOOM						CHANGE DIFFERENTIAL OIL					
CHECK OPERATION OF WINDOWS						CHECK LIFT CYLINDERS FOR LEAKS					
CHECK SEAT BELT OPERATION						CHECK OTTO-RIDE RUBBER ISOLATOR (IF APP.)					
CHECK REAR AND SIDE DOOR LATCH OPERATION						TORQUE REAR AXLE MOUNTING BOLTS					
CHECK DOME LIGHT OPERATION						CHASSIS					
CHECK ALL GLASS AND MIRRORS						CHECK FRONT WHEEL BEARINGS					
CHECK FIRE EXTINGUISHER CHARGE (IF APP.)						CHECK FRONT AXLE OIL LEVEL (IF APP.)					
CAB DOWN – EXTERIOR						REPACK FRONT WHEEL BEARINGS (IF APP.)					
CHECK SIDE DOOR HINGE						CHECK BATTERY CABLES & HOLDDOWNS					
CHECK CAB ACCESS STEPS AND HANDLES						CHECK BATTERIES FOR CRACKS OR DAMAGE					
CLEAN HEATER / AC FILTER						CLEAN BATTERY CABLE CONNECTIONS					
CHECK REAR DOOR ROLLER / SLIDE ADJUSTMENT						CHECK BATTERY BOX COVER HOLDDOWNS					
CHECK GLADHAND SEALS AND TRAILER AIR LINES						DRAIN WATER FROM AIR TANKS					
CHECK TRAILER LIGHT CORD (IF APP.)						CHECK AND TORQUE ALL WHEEL NUTS					
CHECK HEADLIGHTS / MARKER LIGHTS						CHECK WHEELS					
CHECK TURN SIGNALS						CHECK TIRE AIR PRESSURE, TREAD DEPTH & CONDITION					
CHECK STROBE LIGHT (IF APP.)						CHECK REAR AXLE PLANETARY FLUID LEVEL (IF APP.)					
CHECK SPOTLIGHTS						INSPECT PLATFORMS					
CHECK WIPER BLADES						CHECK FRAME FOR CRACKS					
CHECK WINDSHIELD WASHER FLUID LEVEL						CHECK MUD FLAPS / FENDERS (IF APP.)					
CAB UP						CHANGE HYDRAULIC SYSTEM FILTER					
CHECK OPERATION OF CAB TILT PUMP						CHECK HYDRAULIC FLUID LEVEL					
CHECK CAB SAFETY PROP						CHANGE HYDRAULIC FLUID					
CHECK CAB SUSPENSION AND LATCH						CLEAN HYDRAULIC TANK VENT					
CHECK ENGINE INTAKE DUCTING FOR LEAKS						CHECK CAB HINGE PINS AND BUSHINGS					
CHECK RADIATOR FOR LEAKS						LUBRICATION					
CHECK RADIATOR MOUNTS						CHECK / LUBRICATE REAR DOOR ROLLERS					
CHECK COOLANT LEVEL AND CONCENTRATION						CHECK / LUBRICATE HOOD HINGE					
CHECK AND ADJUST COOLANT ADDITIVE (IF APP.)						CHECK / LUBRICATE STEERING SLIP JOINT					
CHANGE ENGINE COOLANT						CHECK / LUBRICATE STEERING U-JOINTS					
CHECK COOLANT HOSES AND CLAMPS						CHECK / LUBRICATE ALL STEERING LUBE POINTS					
CHECK FAN CLUTCH FOR OPERATION (IF APP.)						CHECK / LUBRICATE SLACK ADJUSTERS					
CHECK ENGINE COOLING FAN FOR CRACKS						CHECK / LUBRICATE LEAF SPRING PINS AND BUSHINGS					
CHECK ENGINE BELT(S) AND TENSIONER						CHECK / LUBRICATE DRIVELINE U-JOINTS					
CHANGE ENGINE COOLANT FILTER (IF APP.)						CLEAN, CHECK, ADJUST AND LUBE 5 TH WHEEL JAWS					
CHECK ENGINE AND TRANSMISSION FOR LEAKS						CHECK AND LUBRICATE 5 TH WHEEL TOP PLATE					
DRAIN FUEL WATER SEPARATOR						CHECK AND LUBRICATE 5 TH WHEEL PIVOT PINS					
CHANGE FUEL WATER SEPARATOR						CHECK AND LUBRICATE BOOM PIVOT BEARINGS					
CHECK AIR RESTRICTION GAUGE (IF APP.)						CHECK AND LUBE BOOM CYLINDER BEARINGS					
CHANGE AIR FILTER						CHECK AND LUBRICATE HYDRAULIC PUMP DRIVE (IF APP.)					
CHANGE AIR DRYER DESICCANT (IF APP.)						CHECK AND LUBE OTTO-RIDE PIVOT POINTS (IF APP.)					
CHECK EXHAUST SYSTEM						ADD GREASE TO AUTOLUBE RESERVOIR (IF APP.)					
CHECK TRANSMISSION FLUID LEVEL						TEST DRIVE					
CLEAN TRANSMISSION BREATHER						DRIVE VEHICLE TO CHECK OVERALL OPERATION					
TORQUE CAB TO DECK MOUNTING BOLTS						NOTES:					

OTT0003

Preventive Maintenance Form — Non-Synthetic Transmission Lubrication

**KALMAR TERMINAL TRACTOR PREVENTATIVE MAINTENANCE FORM
2007 OR NEWER ENGINES**

SYNTHETIC (TES-295) LUBE AND ALLISON HIGH-CAPACITY FILTERS USED IN THE TRANSMISSION

TRUCK NUMBER	LOCATION	TECHNICIAN				HOURS	DATE
EACH OF THE FOLLOWING ITEMS SHOULD BE CHECKED AND THE CORRESPONDING BOX MARKED WITH THE APPROPRIATE NOTATION. √ = SATISFACTORY 0 = ADJUSTMENT NECESSARY X = REPAIRS NEEDED. "A" INSPECTIONS SHOULD BE PERFORMED AT 250 HOUR INTERVALS. "B" INSPECTIONS AT 500 HOUR INTERVALS, "C" INSPECTIONS AT 1000 HOUR INTERVALS, AND "D" INSPECTIONS AT 2000 HOUR INTERVALS. SHADED BOXES INDICATE THAT THE OPERATION SHOULD NOT BE DONE AT THAT INTERVAL.							
OPERATION		A	B	C	D	OPERATION	
CAB - INTERIOR						UNDER VEHICLE	
CHECK OPERATION OF NEUTRAL START						CHECK STEERING GEAR	
CHECK OPERATION OF ALL GAUGES						CHECK BRAKE LININGS AND DRUMS	
CHECK LOW AIR BUZZER AND LIGHT						CHECK LEAF SPRINGS	
CHECK WINDSHIELD WIPER OPERATION						CHECK SHOCK ABSORBERS (IF APP.)	
CHECK WINDSHIELD WASHER OPERATION (IF APP.)						TORQUE FRONT AXLE MOUNTING BOLTS	
CHECK THROTTLE OPERATION						TORQUE KING PIN DRAW KEY NUT(S)	
CHECK HORN(S) OPERATION						CHECK HYDRAULIC PUMP	
CHECK AIR SYSTEM. MINIMUM 120 PSI. MAXIMUM 130 PSI						CHECK STARTER MOUNTING AND CONNECTIONS	
CHECK AIR SYSTEM FOR LEAK DOWN						CHECK ENGINE AND TRANSMISSION FOR LEAKS	
CHECK OPERATION OF BACK UP ALARM						CHANGE ENGINE OIL AND FILTER	
CHECK HVAC SYSTEM						CHANGE TRANSMISSION FILTERS	EVERY 3000 HOURS
BLOWER MOTOR OPERATION						CHANGE TRANSMISSION FLUID	EVERY 6000 HOURS
TEMPERATURE CONTROL						CHECK ENGINE AND TRANSMISSION MOUNTS	
DEFROSTER OPERATION						CHECK WHEEL SEALS FOR LEAKS	
A/C OPERATION (IF APP.)						CLEAN REAR AXLE BREATHER	
AUXILIARY FAN(S) (IF APP.)						CHECK DIFFERENTIAL FOR LEAKS	
CHECK 5 TH WHEEL UNLATCH CONTROL						CHECK DIFFERENTIAL OIL LEVEL	
CHECK OPERATION OF BOOM						CHANGE DIFFERENTIAL OIL	
CHECK OPERATION OF WINDOWS						CHECK LIFT CYLINDERS FOR LEAKS	
CHECK SEAT BELT OPERATION						CHECK OTTO-RIDE RUBBER ISOLATOR (IF APP.)	
CHECK REAR AND SIDE DOOR LATCH OPERATION						TORQUE REAR AXLE MOUNTING BOLTS	
CHECK DOME LIGHT OPERATION						CHASSIS	
CHECK ALL GLASS AND MIRRORS						CHECK FRONT WHEEL BEARINGS	
CHECK FIRE EXTINGUISHER CHARGE (IF APP.)						CHECK FRONT AXLE OIL LEVEL (IF APP.)	
CAB DOWN - EXTERIOR						REPACK FRONT WHEEL BEARINGS (IF APP.)	
CHECK SIDE DOOR HINGE						CHECK BATTERY CABLES & HOLDDOWNS	
CHECK CAB ACCESS STEPS AND HANDLES						CHECK BATTERIES FOR CRACKS OR ACID DAMAGE	
CLEAN HEATER / AC FILTER						CLEAN BATTERY CABLE CONNECTIONS	
CHECK REAR DOOR ROLLER / SLIDE ADJUSTMENT						CHECK BATTERY BOX COVER HOLDDOWNS	
CHECK GLADHAND SEALS AND TRAILER AIR LINES						DRAIN WATER FROM AIR TANKS	
CHECK TRAILER LIGHT CORD (IF APP.)						CHECK AND TORQUE ALL WHEEL NUTS	
CHECK HEADLIGHTS / MARKER LIGHTS						CHECK WHEELS	
CHECK TURN SIGNALS						CHECK TIRE AIR PRESSURE, TREAD DEPTH & CONDITION	
CHECK STROBE LIGHT (IF APP.)						CHECK REAR AXLE PLANETARY FLUID LEVEL (IF APP.)	
CHECK SPOTLIGHTS						INSPECT PLATFORMS	
CHECK WIPER BLADES						CHECK FRAME FOR CRACKS	
CHECK WINDSHIELD WASHER FLUID LEVEL						CHECK MUD FLAPS / FENDERS (IF APP.)	
CAB UP						CHANGE HYDRAULIC SYSTEM FILTER	
CHECK OPERATION OF CAB TILT PUMP						CHECK HYDRAULIC FLUID LEVEL	
CHECK CAB SAFETY PROP						CHANGE HYDRAULIC FLUID	
CHECK CAB SUSPENSION AND LATCH						CLEAN HYDRAULIC TANK VENT	
CHECK ENGINE INTAKE DUCTING FOR LEAKS						CHECK CAB HINGE PINS AND BUSHINGS	
CHECK RADIATOR FOR LEAKS						LUBRICATION	
CHECK RADIATOR MOUNTS						CHECK / LUBRICATE REAR DOOR ROLLERS	
CHECK COOLANT LEVEL AND CONCENTRATION						CHECK / LUBRICATE HOOD HINGE	
CHECK AND ADJUST COOLANT ADDITIVE (IF APP.)						CHECK / LUBRICATE STEERING SLIP JOINT	
CHANGE ENGINE COOLANT						CHECK / LUBRICATE STEERING U-JOINTS	
CHECK COOLANT HOSES AND CLAMPS						CHECK / LUBRICATE ALL STEERING LUBE POINTS	
CHECK FAN CLUTCH FOR OPERATION (IF APP.)						CHECK / LUBRICATE SLACK ADJUSTERS	
CHECK ENGINE COOLING FAN FOR CRACKS						CHECK / LUBRICATE LEAF SPRING PINS AND BUSHINGS	
CHECK ENGINE BELT(S) AND TENSIONER						CHECK / LUBRICATE DRIVELINE U-JOINTS	
CHANGE ENGINE COOLANT FILTER (IF APP.)						CLEAN, CHECK, ADJUST AND LUBE 5 TH WHEEL JAWS	
CHECK ENGINE AND TRANSMISSION FOR LEAKS						CHECK AND LUBRICATE 5 TH WHEEL TOP PLATE	
DRAIN FUEL WATER SEPARATOR						CHECK AND LUBRICATE 5 TH WHEEL PIVOT PINS	
CHANGE FUEL WATER SEPARATOR						CHECK AND LUBRICATE BOOM PIVOT BEARINGS	
CHECK AIR RESTRICTION GAUGE (IF APP.)						CHECK AND LUBE BOOM CYLINDER BEARING	
CHANGE AIR FILTER					AS NEEDED	CHECK AND LUBRICATE HYDRAULIC PUMP DRIVE (IF APP)	
CHANGE AIR DRYER DESICCANT (IF APP.)					AS NEEDED	CHECK AND LUBE OTTO-RIDE PIVOT POINTS (IF APP.)	
CHECK EXHAUST SYSTEM						ADD GREASE TO AUTOLUBE RESERVOIR (IF APP.)	
CHECK TRANSMISSION FLUID LEVEL						TEST DRIVE	
CLEAN TRANSMISSION BREATHER						DRIVE VEHICLE TO CHECK OVERALL OPERATION	
TORQUE CAB TO DECK MOUNTING BOLTS						NOTES:	

OTT0004

Preventive Maintenance Form — Synthetic Transmission Lubrication with High Capacity Filters

0.4 Preventive Maintenance Technique

General

The following is more detailed information for preventive maintenance. See the Lubrication Points page 5 provided in this manual. Refer to the Preventive Maintenance Forms page 9 and page 10 for additional scheduling. The hourly time limits described in this manual are absolute maximums. Harsh vehicle usage may dictate shorter intervals. Inspect frequently to discover where changes may be necessary.

0.4.1 Fuel, Filters, Fluids and Lubricants

Maintenance

The engine, transmission and axle manufacturers provide maintenance information and specify fluids and lubricants to be used in their products. Comply with the original equipment manufacturer's specifications in order to maintain warranty coverage.

Follow the periodic checklists as indicated. Fill reservoirs as necessary using specified fluids. When adding, use the same fluid as is in the reservoir. If the fluid is unknown, drain and replace it according to specification.

Use only the fuel, coolant, coolant additives and lubricants specified by the engine manufacturer.

Follow the engine manufacturer's specification for the coolant and water ratio or maintain engine coolant freeze protection at approximately -34°F (-37°C). Determine the reason for lost fluid. Repair as necessary.

The Kalmar Parts Catalog is customized to the vehicle. Refer to this catalog for filter part numbers.

Kalmar recommends API Grade 1 grease, any high quality lithium-based grease, or a base oil with a Timken 40 minimum rating for use in axles. Install the same lubricant as originally installed in the axles.

Do not use lithium grease on front axles equipped with "WET" wheel seals. The front hubs must be inspected after every 250 hours of operation.

Power steering, the boom lift and the cab tilt mechanism all use hydraulic fluid stored in a single tank mounted on the rail. A vehicle being operated in a severe application may require shorter intervals between changes. The system filter is on the hydraulic tank.

0.4.2 Cab Interior

Maintenance

Neutral Start — Move the gear selector to any position other than “N” and attempt to start the engine. The engine **should not** crank with the selector in any position other than “N.”

All Gauges — With the engine running, verify that all gauges are functional.

Low Air Buzzer and Light — Apply and release the brake pedal until air pressure drops below 90 PSI. At that point, the low air buzzer and dash warning light should come on.

Windshield Wiper Operation — Turn on the windshield wiper and confirm full and smooth travel of the wiper arm. Listen for noises that might indicate a worn wiper motor.

Windshield Washer Operation (If Applicable) — Depress the washer button and confirm the flow and pattern of the washer fluid.

Throttle Operation — Depress and release the foot throttle and check for binding and ease of operation.

Horn(s) Operation — Sound electric and air horns (if applicable) to confirm proper operation.

Air System — Start the engine and run at fast idle. Maximum system pressure should be between 120 PSI and 130 PSI.

Air System Leak Down — Disconnect the glad hands from the trailer. Run the engine at fast idle and allow air pressure to stabilize at 120 PSI for at least one minute. Shut off the engine and observe the dash gauge(s) for two minutes. The drop in pressure should not exceed 2 PSI over the two-minute period.

Backup Alarm — With the engine running, move the gear selector to reverse and listen for the backup alarm.

HVAC System —

- **Blower Motor Operation**

With the key on, ensure that the blower motor operates at each position of the blower speed switch.

- **Temperature Control**

Confirm proper operation of the temperature control switch.

- **Defroster Operation**

With the engine running and the defroster control turned on, confirm air flow from the defroster vents.

- **Air Conditioner Operation**

With the engine running and the air conditioner control turned on, confirm cooled air flow from the vents.

- **Auxiliary Fan(s) (If Applicable)**

With the key on, turn on the auxiliary fans and confirm operation.

Fifth-Wheel Unlatch Control — With system air pressure above 100 PSI, confirm that the fifth-wheel jaws unlatch when the dash control is activated.

Boom — With the engine running at fast idle, activate the boom control and verify full extension and retraction.

Windows — Confirm that all regulated and sliding windows open and close fully.

Seat Belt Operation — Verify that the seat belt latch fastens and unfastens properly.

Rear and Side Door Latch Operation — Operate the side door latch from inside and outside the cab to ensure proper operation.

Dome Light Operation — With the key on, turn on the cab dome light and confirm operation.

All Glass and Mirrors — Inspect all glass and mirrors for cracks and breaks.

Fire Extinguisher Charge (If Applicable) — If the vehicle is equipped with a fire extinguisher, confirm that it is properly charged.

0.4.3 Cab Down — Exterior

Maintenance

Side Door Hinges — Inspect the door hinge for wear and damage.

Cab Access Steps and Handles — Inspect all steps and grab handles for proper mounting and the absence of cracks.

Heater/AC Filter — Remove the HVAC filter and vacuum or blow clean with low-pressure air.

Rear Door Roller/Slide Adjustment — Inspect the roller and slide adjustment for wear and damage.

Glad-Hand Seals and Trailer Air Lines — Inspect seals for tears and wear. Check air lines for kinks or cracks.

Trailer Light Cord (If Applicable) — Inspect light cord for cuts and abrasions. As the lights of the truck are checked, confirm that a trailer connected with the light cord also has lights. This can be done either with a trailer connected or with a “test box”.

Headlights/Marker Lights — Start the engine, turn on light switches and confirm lights are burning.

Turn Signals — With the key on, activate the turn signal switch and the flasher to confirm that the turn signals are working.

Strobe Light (If Applicable) — With the key on, turn on the strobe light to confirm its operation.

Spotlights — With the key on, turn on the spotlight(s) to confirm its operation.

Wiper Blades — Inspect wiper blades for tears or excessive wear.

Windshield Washer Fluid Level (If Applicable) — Fill the washer bottle as necessary.

0.4.4 Cab Up

Maintenance

Cab Tilt Pump — Pull the cab release cable and activate the cab tilt switch. The cab should rise.

Cab Safety Prop — Inspect the cab safety prop that encloses the cab lift cylinder. It should drop freely into place to support the cab when it is in the raised position. The lower cab cylinder pin and bracket should be inspected for signs of fatigue.

Cab Suspension and Latch — Inspect the linkages of the suspension system for excessive wear and proper alignment. Inspect the air bag for leaks or signs of abrasion. Inspect the lock jaw for excessive wear and proper operation.

Intake Ducting for Leaks — Inspect all engine clean air tubes and hoses for leaks. All clamps should be checked for proper torque and all joints should be properly aligned.

Radiator for Leaks — Inspect the radiator core and tanks for signs of coolant leaks.

Radiator Mounts — Inspect the radiator mounts for wear or excessive looseness.

Coolant Level and Concentration — Check the cooling system level. Coolant should be visible in the radiator sight glass. It is not necessary for the coolant to be at the top of the sight glass. Test and maintain the proper antifreeze level of concentration as outlined in the appropriate engine operator's manual.

Coolant Additive (If Applicable) — Using the appropriate test method for the diesel coolant additive (DCA) or supplemental coolant additive (SCA) being used (e.g., Nalcool), maintain the recommended level of concentration as outlined in the applicable engine operator's guide.

Change Engine Coolant — Flush the cooling system and replace with clean coolant of the appropriate concentration.

Coolant Hoses and Clamps — Inspect all hoses for abrasion, cracks, holes and routing. Check all clamps for proper torque.

Fan Clutch for Operation (If Applicable) — Run the engine to confirm that the fan clutch engages at the proper temperature.

Engine Cooling Fan for Cracks — Shut the engine off if running. Inspect fan blades for signs of cracking.

Engine Belts and Tensioner — Inspect belt(s) for cracking and wear. The belt tensioner should be checked for proper operation.

Change Engine Coolant Filter (If Applicable) — Replace the engine coolant filter. A filter containing the proper SCA should be used to maintain the specified concentration level.

Engine and Transmission for Leaks — Perform a visual inspection of the engine and transmission looking for fluid leaks visible from above.

Drain Fuel/Water Separator — Open the drain valve on the fuel/water separator and allow water to drain from the filter.

Change Fuel/Water Separator — Replace the fuel filter following the instructions in the engine operator's manual.

Air Restriction Gauge (If Applicable) — Record the reading on the gauge, reset, start the engine, run to high idle and shut off the engine. If the reading remains zero, the gauge may be defective or the intake piping has a leak. Discover the cause and repair or replace parts as necessary.

If the initial gauge reading indicates that the filter should be changed, do so at this time.

Change Air Filter — The air filter should be changed as necessary. If the truck is equipped with a restriction gauge, replace the filter when the gauge indicates.

Change Air Dryer Desiccant (If Applicable) — The desiccant should be changed as necessary. Change as soon as water is evident when the system air tanks are drained.

Exhaust System — Visually inspect all of the exhaust system components for leaks and/or damage.

Transmission Fluid Level — With the engine running, use the transmission dipstick to check the fluid level per the guidelines in the transmission operator's manual.

Clean Transmission Breather — Confirm that the breather, located on top of the transmission, is clean and the passage is open. Do not spray directly with high pressure or cleaning solvents.

Tighten Cab-to-Deck Mounting Bolts — Tighten the cab-to-deck fasteners.

0.4.5 Under Vehicle

Maintenance

Steering Gear — Inspect the steering gear for fluid leaks and excessive play. Inspect the steering linkage for wear or looseness.

Brake Linings and Drums — Visually check linings and drums for wear and cracks. If the lining is 0.25 inch (6.4 mm) thick or less in any location, the shoes should be replaced or relined.

Leaf Springs — Inspect leaf springs for cracking or excessive deflection. Inspect spring pins and shackles for wear.

Shock Absorbers (If Applicable) — Inspect shock absorbers for leaks.

Tighten Front Axle Mounting Bolts — Tighten front axle mounting bolts.

Tighten King Pin Draw Key Nuts — Tighten steer axle king pin draw key nuts.

Hydraulic Pump — Inspect the hydraulic pump for leaks.

Starter Mounting and Connections — Confirm that starter mounting bolts are tight. Inspect electrical connections for good contact at starter terminals.

Engine and Transmission for Leaks — Perform a visual inspection of the engine and transmission looking for fluid leaks visible from below.

Change Engine Oil and Filter — Drain and replace the engine oil. Use oil that meets or exceeds the minimum specifications in the engine operator's manual. Replace the oil filter.

Change Transmission Filters — Follow transmission manufacturer's procedures.

NOTE

*This does **NOT** include the pan screen. The screen should only be replaced during overhaul.*

Change Transmission Fluid — Drain and replace the transmission fluid. Use fluid that meets or exceeds the minimum specifications provided in the transmission operator's manual.

Engine and Transmission Mounts — Tighten the engine and transmission mounts. Inspect isolator material and replace if deteriorated.

Wheel Seals for Leaks — Inspect the front and rear hubs for signs of oil leaks. Replace if leaking.

Rear Axle Breather — Ensure that the rear axle vent turns freely.

Differential — Inspect the rear axle housing for signs of leaks. Repair as necessary.

Differential Oil Level — Check the differential oil level per the component manufacturer's instructions.

Change Differential Oil — Drain and replace differential oil. Use oil that meets or exceeds the minimum specifications of the component manufacturer.

Lift Cylinders — Inspect cylinders for leaks. Repair as necessary.

Otto-Ride Rubber Isolator (If Applicable) — Inspect the isolator for signs of cracking or loss of elasticity. Replace as necessary.

Rear Axle Mounting Bolts — Tighten rear axle mounting bolts.

0.4.6 Chassis

Maintenance

Front Wheel Bearings — Raise and support the front axle. Check for excessive play in wheel bearing.

Front Axle Oil Level (If Applicable) — Check the oil level in the front axle hubcaps. Fill to proper level as necessary.

Front Wheel Bearings (If Applicable) — Remove front hubs and repack the bearings using grease that meets or exceeds the minimum specifications of the component manufacturer.

Battery Cables and Holddowns — Inspect the battery for signs of abrasion or breaking. Repair and reroute as necessary. Ensure that the batteries are properly secured.

Batteries — Inspect the batteries for signs of damage. Replace as necessary.

Battery Cable Connections — Remove the cable terminals from batteries, clean connections, reattach cable terminals.

Battery Box Cover Holddowns — Check the bolts or rubber latches to ensure that the battery box cover is secured.

Air Tanks — With the air system charged, open each manual drain until all moisture is removed from the system.

All Wheel Nuts — Inspect all wheel nuts for signs of wear or damage.

Wheels — Inspect all wheels for signs of damage including oversized holes and cracks.

Tires — Inspect tires for damage and wear. Adjust to the air pressure specified for the tire.

Rear Axle Planetary Housing (If Applicable) — Check and adjust the lubricant level in the planetary housings per the component manufacturer's instructions.

Platforms — Inspect the platforms for proper mounting and the absence of cracks and trip points.

Frame — Inspect the frame rails and cross members for cracks and bending.

Mud Flaps/Fenders (If Applicable) — If equipped with mud flaps and or fender, inspect these items for proper mounting and damage.

Change Hydraulic System Filter — Remove and replace the external hydraulic filter.

Hydraulic Fluid Level — Start the engine, raise and lower the boom twice to ensure that the system components are filled. Lower the boom to full down position, shut off the engine and check the fluid level on the tank gauge. Fill as necessary.

Change Hydraulic Fluid — Drain the hydraulic tank and refill with the specified hydraulic fluid.

Hydraulic Tank Vent — Remove dirt collecting around the vent and ensure that the vent is clear.

Cab Hinge Pins and Bushings — Inspect pins and bushings for wear or damage.

0.4.7 Lubrication

Maintenance

Rear Door Rollers — Inspect upper rollers. Replace if binding or damaged. Lubricate.

Hood Hinge — Inspect the hood hinge for wear and damage. Lubricate.

Steering Slip Joint — Inspect the slip joint for wear or damage. Lubricate.

Steering U-Joints — Inspect the u-joints for wear or damage. Lubricate.

Steering Lube Points — Inspect king pins, tie rod ends and drag link ends for wear or damage. Lubricate.

Slack Adjusters — Inspect the brake slack adjusters for wear or damage. Measure the brake actuator stroke. If this measurement exceeds the component manufacturer's specification, check the brake lining and adjuster to determine the cause of the excessive stroke and repair as necessary.

Leaf Spring Pins and Bushings — Inspect spring pins, hangers and pin bushings for wear or damage. Lubricate.

Driveline U-Joints — Inspect driveline and u-joints for wear or damage. Lubricate.

Fifth-Wheel Jaws — Remove dirt and excessive grease from the fifth-wheel jaws. Using a fifth-wheel jaw gauge, measure the free play. If free play exceeds 1/8 inch (3.2 mm), determine the cause and repair or replace the jaws per the component manufacturer's recommendation.

Fifth-Wheel Top Plate — Clean and inspect the fifth-wheel top plate for cracks or other damage. Apply grease to the surface of the top plate.

Fifth-Wheel Pivot Pins — Inspect fifth-wheel pivot pins for wear or damage. Lubricate.

Boom Pivot Bearings — Inspect boom pivot bearings for wear or damage. Lubricate.

Boom Cylinder Bearings — Inspect boom cylinder bearings for wear or damage. Lubricate.

Hydraulic Pump Drive (If Applicable) — (Applies only to trucks built prior to March 2007) Remove the hydraulic pump from the PTO. Inspect the splined coupling shaft for wear. On units equipped with a zerk fitting, removal of the PTO is not necessary. Lubricate.

Otto-Ride Pivot Points (If Applicable) — Inspect all Otto-Ride pivot points for wear or damage. On Otto-Ride systems equipped with a single point lube system, inspect lube lines to ensure delivery of lubricant to all points. Depending on the type of lube system, lubricate the single point or each pivot point.

Autolube Reservoir — If the vehicle is equipped with an automatic lubrication system, inspect all lubrication points for sufficient grease. Fill the system reservoir with the proper type and quantity of grease per the component manufacturer's recommendation.

0.4.8 Test Drive

Maintenance

Overall Operation — Start and drive the vehicle. Test the operation of all systems and components.

– 0. Machine Complete

0.1 The Ottawa Terminal Tractor

Description

The Ottawa terminal tractor by Kalmar is designed to suit the operator *and* the tasks. Ottawa tractors are purpose-built vehicles, designed to move trailers in the most efficient manner. Controls are conveniently arranged around the operator's seat. The operator can get into the cab from the side or through the sliding rear door. The sliding feature and latching in open and closed position means that the rear door is never in the way. Full-length grab-handles, large windows and easy access to all operator controls are some of the features of the efficiently designed cab.

The trailer air lines and electrical connections are easily accessible through the rear door. Perforated decking allows the operator to move from cab to trailer comfortably and easily. A hydraulically powered boom under the fifth wheel raises a trailer high enough to allow it to be moved without raising and lowering its landing gear. These features along with in-cab fifth-wheel release and automatic relatch means that the operator is not required to climb up and down from the cab for every trailer move.

The Ottawa also features automatic transmissions, hydraulic cab tilt for easy maintenance access, a short turning radius and matched drive train components with durable axles that simplify maintenance even further. Ottawa tractors are engineered for longevity and easy operation.

0.2 Diesel Fuel Requirements

Precautions



WARNING

Do NOT smoke when handling diesel fuel. Failure to heed this warning may result in serious personal injury and property damage.

Use only the fuel specified by the engine manufacturer. Improper fuel can result in corrosion, damaging deposits and premature wear.



CAUTION

Do NOT add anything but diesel fuel to the fuel tank. Drain the entire fuel system and fill with the correct fuel. Failure to heed this caution may result in serious property damage.

Avoid using smoke suppressant additives to prevent excessive ash deposits that may result in frozen rings and guttered valves. Refer to the engine manufacturer's service manual for fuel requirements.

0.3 Emergency Starting

Precautions

When jump starting one vehicle from another, both electrical systems must have the same voltage rating and polarity.



CAUTION

Verify that the polarity and voltage rating of the service batteries match the polarity and voltage rating of your Ottawa tractor before attempting to jump start a vehicle.

Due to the higher torque requirements for starting diesel engines, Ottawa tractors use multiple batteries. At low temperatures, it may not be possible to start the engine in an Ottawa tractor using only one battery.



CAUTION

Never tow a vehicle in an attempt to start the engine. This may cause serious damage to the automatic transmission.

Jump Starting Instructions

1. Position the vehicles so that the jumper cables reach comfortably but the vehicles do **NOT** touch. Ensure that the jumper cable insulation is **NOT** missing or loose.
2. Shift the automatic transmission to neutral and apply the parking brake.
3. Turn off the ignition switch and all lights and accessories in both vehicles.
4. Make sure the cable clamps do not touch other metal parts. Clamp one end of the first jumper cable to the positive terminal on one battery and the other end to the positive terminal on the other battery. **NEVER connect positive to negative.**
5. Clamp one end of the second cable to the negative terminal of the charged battery and the other end to the negative terminal of the dead battery.
6. Start and run the engine of the vehicle with the charged battery at moderate speed for several minutes, then start the engine in the vehicle that has the discharged battery.

7. Remove the jumper cables by reversing the above installation sequence exactly. While removing each clamp be sure that it does not touch any other metal while connected to the other battery.



WARNING

Batteries produce explosive gases, contain corrosive acid and generate levels of electrical current high enough to cause burns.

To reduce the risk of personal injury when working near a battery:

- **WEAR SAFETY GLASSES** and avoid leaning over a battery whenever possible.
- **Do NOT** expose a battery to open flames or sparks.
- **Ensure** that batteries with fill caps are properly filled with fluid.
- **Do NOT** allow battery acid to contact eyes or skin. Flush any contacted area thoroughly with water immediately and seek medical attention.

Failure to heed this warning may result in serious personal injury and property damage.

0.4 Vehicle Towing

Precautions

Use proper equipment to prevent damage to vehicles during towing. Conform to applicable state and local laws for towing vehicles. Vehicles should not be towed at speeds in excess of 55 MPH (89 km/h). Connect towing equipment to main structural parts of the vehicle. See Operator's Manual for more detailed instructions.



CAUTION

Do NOT connect towing equipment to the bumper. Use tow hooks or tow eyes built into the frame. Use only towing equipment designed for the purpose. Follow the instructions of the wrecker manufacturer. Use safety chains. Failure to heed this caution may result in serious property damage.

Secure all loose and protruding parts of the vehicles prior to towing.

Do NOT stand or work under an elevated vehicle without adequate safety stands.

Do NOT attempt towing operations that will jeopardize the safety of other motorists, bystanders or the towing or towed vehicles.

Front End Towing (Front Wheels Off the Ground)

To relocate a disabled vehicle by front end towing with front wheels raised off the ground, follow these steps.

1. Block the rear wheels of the disabled vehicle.
2. Release the parking brake as outlined in the brake section of this manual.

See Caging the brakes in the Operator's Manual or the section on caging the brakes in this manual if there is no air pressure in the system.

3. Disconnect the propeller shaft at the axle.
4. Secure the propeller shaft to the frame or cross member.
5. Remove the axle shafts if there is damage or suspected damage to the axle(s).
6. Cover the hub openings to prevent loss of lubricant or entry of dirt or foreign objects.

When the vehicle has arrived at its destination, ensure it is safely positioned.

1. Block the rear wheels.
2. Install the axle shafts.
3. Remove the covers from the hub openings.
4. Align the universal joints and connect the propeller shaft.
5. Apply the parking brake before disconnecting the towing vehicle.
6. Check and fill rear axles with oil as needed.

Front End Towing (All Wheels On the Ground)

The vehicle may be towed with all wheels on the ground provided the steering system is operating normally. Remember that the steering will not have power assist and the vehicle will not have brakes. A tow bar must be used between the towing and the disabled vehicle.

To relocate a disabled vehicle by towing with all wheels on the ground, follow the procedure described above for towing with front wheels off the ground.

Rear End Towing

When towing the vehicle with rear wheels raised, secure the steering wheel to maintain straight ahead position. Ensure that the front axle load is not more than the gross axle weight rating as indicated on the vehicle identification plate.

0.5 Vehicle Modifications

Approval

Do not modify your Ottawa tractor without approval in writing from Cargotec Solutions LLC, Kalmar Terminal Tractors. Unauthorized modifications may void the vehicle warranty.

0.6 Vehicle Identification

Identification Plate

A vehicle may be specifically identified by referring to the vehicle identification plate. The plate is located inside the cab on the top of the driver's door frame at the rear. This plate shows the model, serial number and manufactured date for this vehicle.

MODEL	SERIAL NO.	MFG. DATE
<input type="text"/>	<input type="text"/>	<input type="text"/>
Cargotec Solutions LLC 415 E. Dundee Street Ottawa, Kansas, USA 66067		

Certification Label

The certification label is supplied only for vehicles qualified under EPA/DOT regulations. It is located inside the cab on the post behind the driver's door. The certification label shows the vehicle type and date of manufacture. Also shown are the Vehicle Identification Number (VIN), gross vehicle weight rating (GVWR), front and rear gross axle weight ratings (GAWR), wheel base, tire and rim sizes, and tire air pressure.

MANUFACTURED BY Cargotec Solutions LLC	
VEHICLE TYPE:	DATE OF MFG:
<input type="text"/>	<input type="text"/>
VIN:	
<input type="text"/>	<input type="text"/>
GVWR:	WHEEL BASE:
<input type="text"/>	<input type="text"/>
GAWR FRONT:	TIRES: RIMS: AT PSI COLD DUAL
<input type="text"/>	<input type="text"/>
GAWR REAR:	TIRES: RIMS: AT PSI COLD DUAL
<input type="text"/>	<input type="text"/>
THIS VEHICLE CONFORMS TO ALL APPLICABLE FEDERAL MOTOR VEHICLE SAFETY STANDARDS IN EFFECT ON THE DATE OF MANUFACTURE SHOWN.	
	
415 EAST DUNDEE STREET, OTTAWA, KANSAS, USA.	

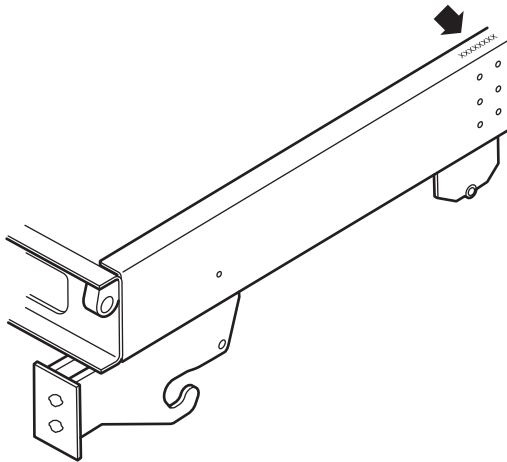

OTT0011

Vehicle Serial Number

The serial number is located on top of the left frame rail inboard of the cab air spring (above the rear spring hanger) and also on the identification plate (see above). Always refer to this number when ordering parts or requesting field service assistance.

Engine Serial Number

Cummins serial numbers are located on the top of the valve cover. Caterpillar serial numbers are located on the rear of the engine on the left-hand side.

0.7 Component Location

0.7.1 Chassis/Cab, Left Side

Ottawa Series, Left Side (4x2 chassis shown)

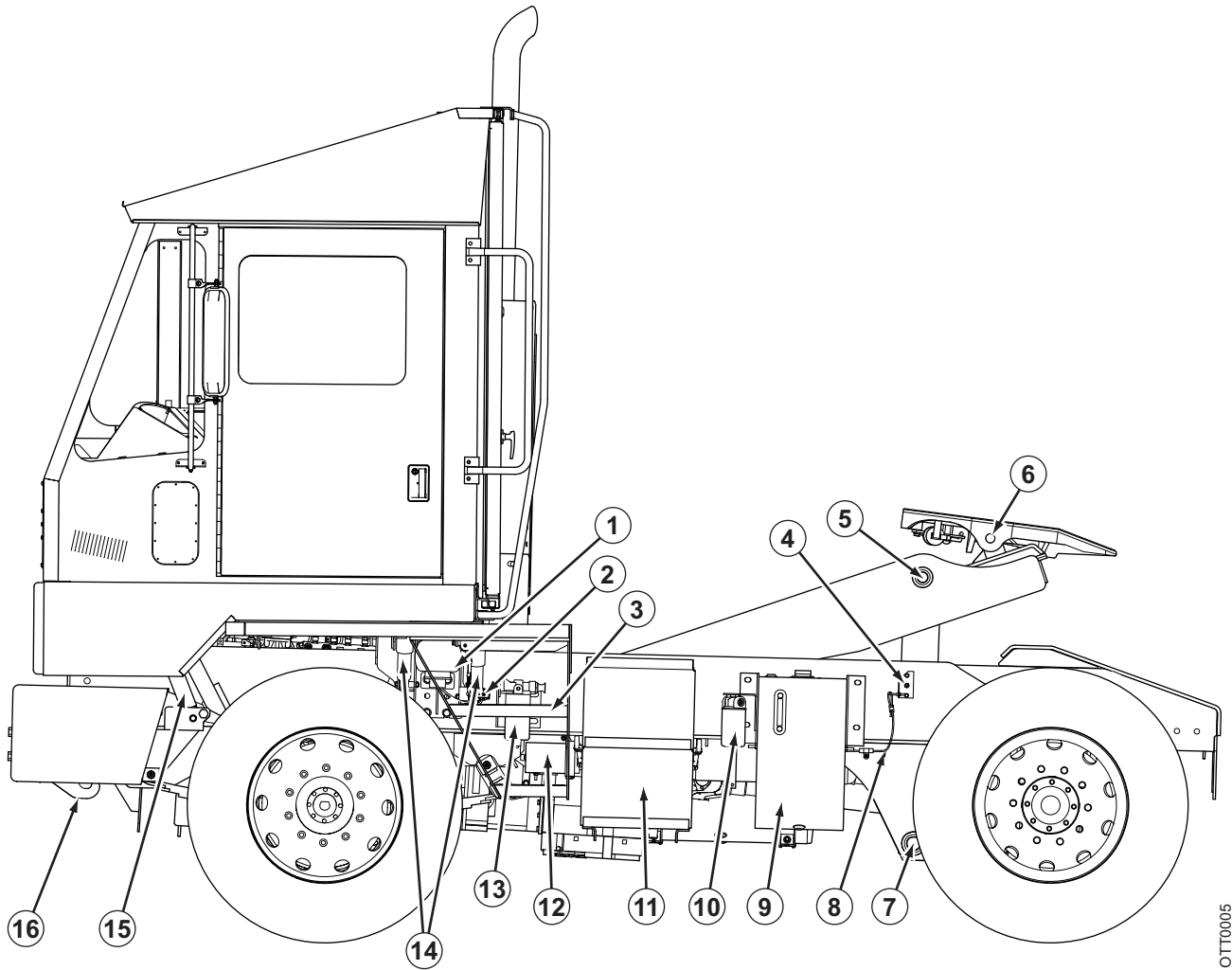

OTT0005

1. Cab Air Ride Air Spring
2. Height Control Valve Assembly
3. Side Entry Ladder
4. Cab Tilt Switch
5. Boom Lift Cylinder Upper Mount
6. Fifth-Wheel Pivot
7. Boom Lift Cylinder Lower Mount
8. Cab Tilt Lanyard
9. Hydraulic Fluid Tank
10. Hydraulic Fluid Filter
11. Battery Box — BOC Steps

- 12. Cab Tilt Pump
- 13. Fuel Filter
- 14. Cab Air Ride Shock Absorber
- 15. Cab Tilt Cylinder Safety Bar
- 16. Tow Hook

0.7.2 Chassis/Cab, Right Side

Ottawa Series, Right Side (4x2 chassis shown)

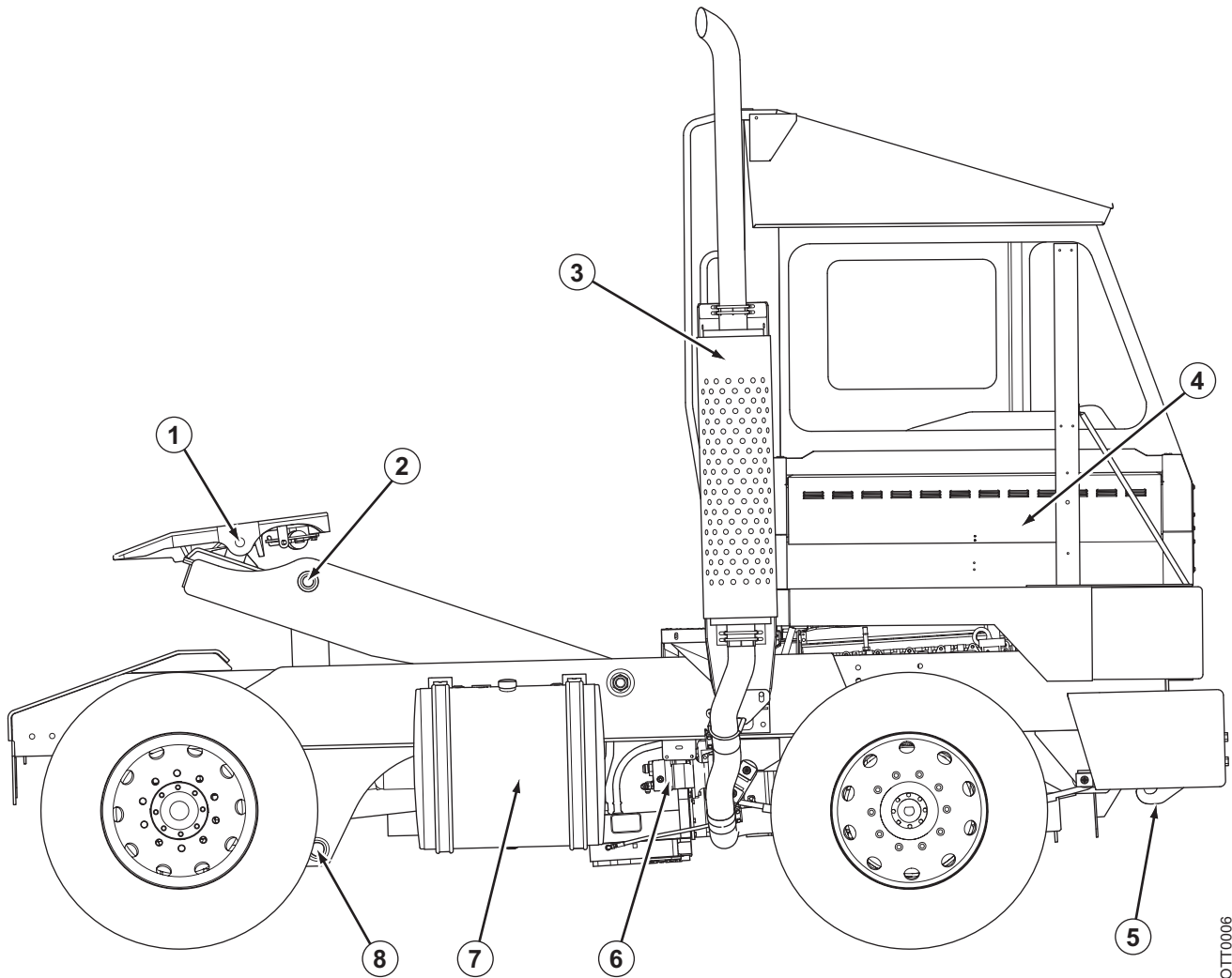

- 1. Fifth-Wheel Pivot
- 2. Boom Lift Cylinder Upper Mount
- 3. Vertical Muffler and Exhaust Pipe
- 4. Engine Access Panel
- 5. Tow Hook
- 6. Hydraulic System Pump
- 7. Fuel Tank

OTT0006

8. Boom Lift Cylinder Lower Mount

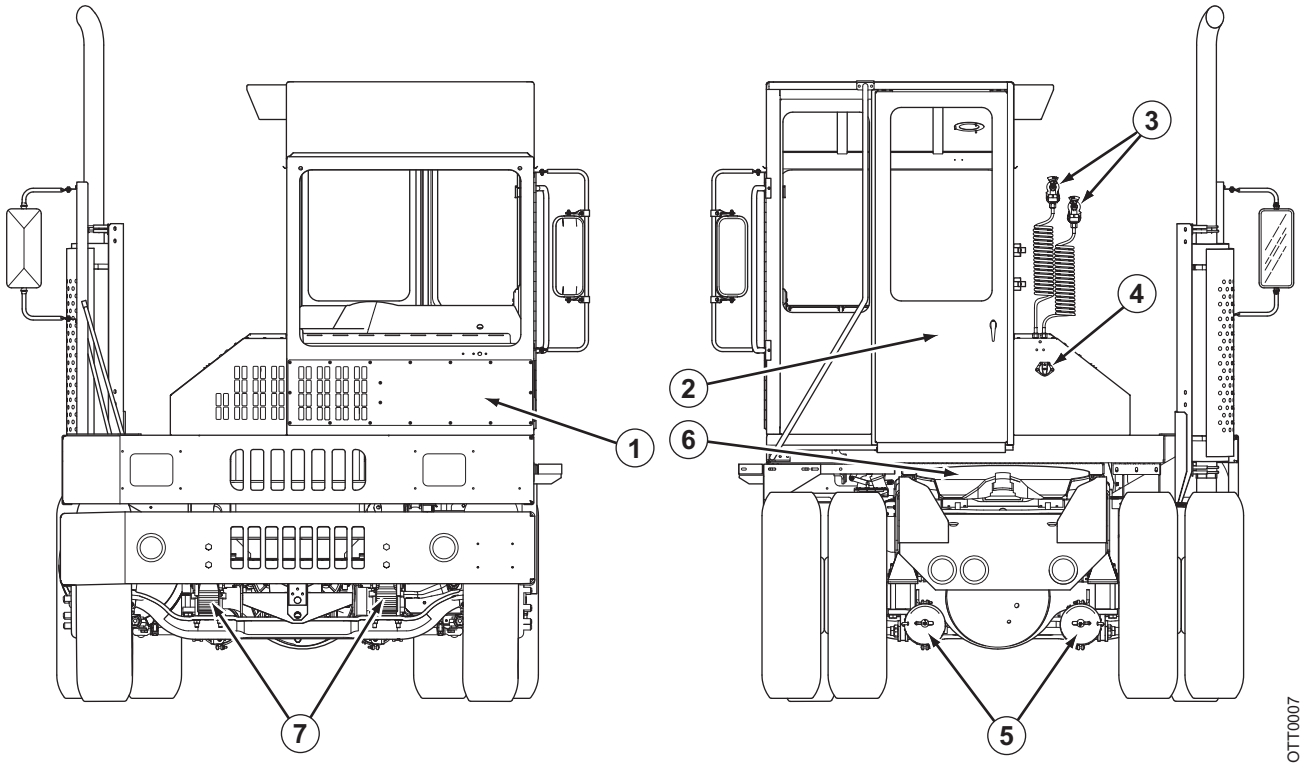
0.7.3 Chassis/Cab, Front/Rear**Ottawa Series, Front/Rear (4x2 chassis shown)**

OTT0007

1. Front Panel (Removable)
2. Rear Door
3. Glad Hands (Air Brake)
4. Trailer Electrical Connector (7-pin)
5. Air Brake Chambers (Rear Axle)
6. Fifth-Wheel
7. Front Leaf Springs

0.7.4 Chassis, Plan View

Ottawa Series, Plan View (4x2 chassis shown)

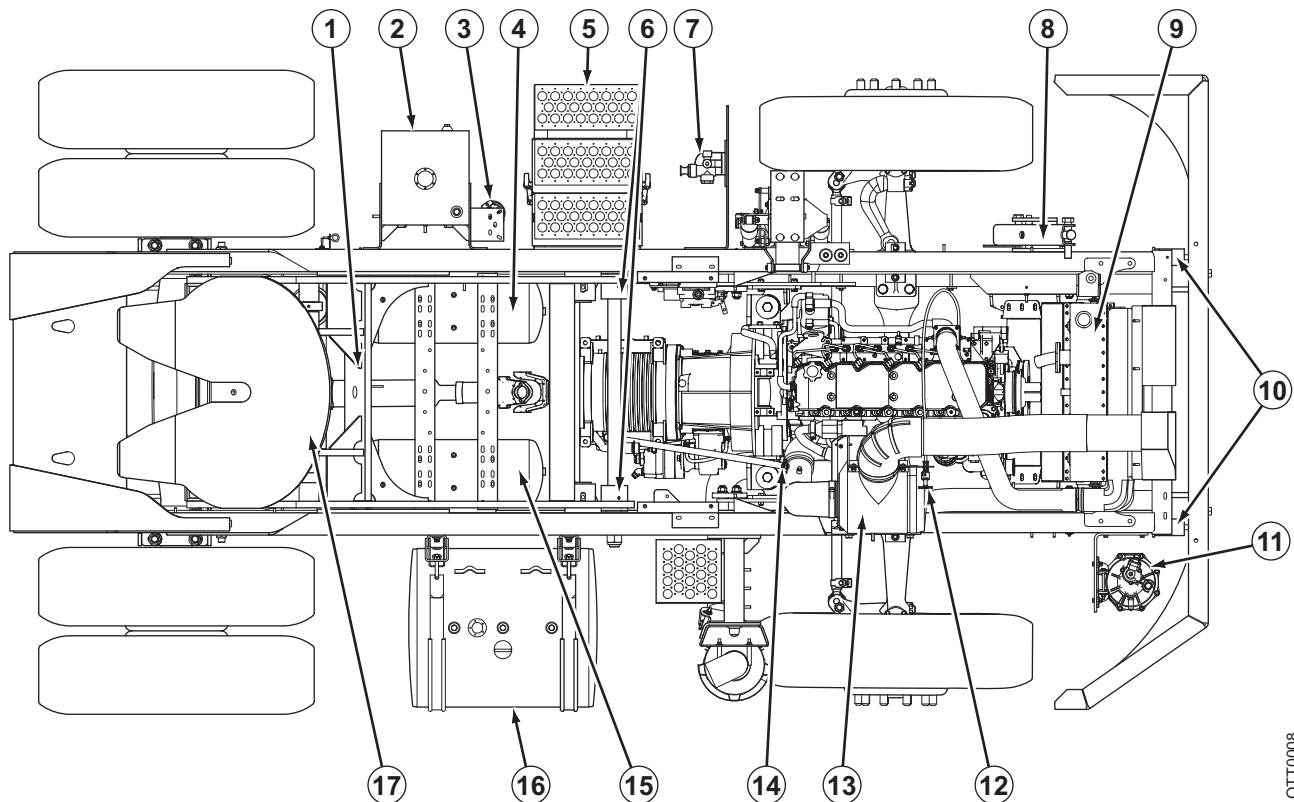

1. Fifth-Wheel Boom
2. Hydraulic Fluid Tank
3. Hydraulic Fluid Filter
4. Air Tank, Service (Air Brakes)
5. Battery Box — BOC Steps
6. Boom Pivot
7. Fuel Filter
8. Cab Lift Cylinder
9. Radiator/Charge Air Cooler
10. Cab Pivots
11. Optional Air Dryer
12. Engine Oil Dipstick
13. Air Cleaner
14. Transmission Fluid Dipstick
15. Air Tank, Supply (Air Brakes)
16. Fuel Tank
17. Fifth-Wheel

OTT0008

0.8 Electrical Instruments

Guide to Troubleshooting

This guide is provided for diagnosis of problems in Kalmar electrical instruments. The sequence presented is intended to minimize duplication. Follow the sequence as described to prevent misdiagnosis. This guide presumes that senders and gauges are properly matched and wired and that the correct voltage is applied.



WARNING

Ensure that the gauges and senders are matched and properly wired in circuits with correct voltage. Failure to heed this warning could result in personal injury and property damage.

Basic Gauge Diagnostic Procedure

Schematics and diagrams of the electrical circuitry appear in *Section E, Schematics*.

The following steps describe the general path to follow when troubleshooting electrical faults that show up on instrument panel gauges.

1. On replacement parts, check the part numbers of the gauge and sender to ensure they are matched, and match the voltage in the vehicle (12 VDC or 24 VDC).
2. Inspect the wiring between the gauge and sender. Wiring should be intact and tightly connected. Tighten and replace wiring as required.
3. If the gauge still does not work, ensure that the steel housing of the sender is properly seated. Provide a three-wire jumper to bypass the system wiring. Connect ignition (or accessory) voltage to the "I" terminal on the back of the gauge. Connect the system ground wire to the "G" terminal and the sender signal lead to the "S" terminal.
 - A. Without power, the gauge pointer may indicate any value. Often, it will indicate the previous signal from the sender.
 - B. Turn on the ignition without starting the engine. The pointer should indicate zero or full PSI. If the pointer indicates outside the endpoints, go to step 3Bc below. If the pointer falls within the endpoints, go to step 3Bd below.

- a. If the pointer is stuck noticeably outside dial scale endpoints, lightly tap the lens. If tapping results in the pointer moving to an acceptable position, look for an open in the sender circuit or replace the gauge. Go to step 3Bc below.
- b. If the pointer rests significantly toward the far left of the scale, remove power to the gauge. Remove the sender wire from "S" terminal on the back of the gauge. Momentarily apply power to the gauge. If the pointer does not travel to the far right of the scale, replace the gauge.
- c. If the pointer rests significantly toward the far right of the scale, remove power to the gauge. Remove the sender wire from "S" terminal on the back of the gauge. Test the resistance of the sender and its wiring using an ohmmeter. The reading should be between 0-250 ohms. If the resistance is more than 250 ohms, check the sender wiring to sender housing or flange grounding. Also, look for an open in the sender wiring circuit. If the electrical wiring is correct and properly grounded, remove the sender and test the sender resistance independent of the installation. If it is not within specifications, replace the sender.
- d. If the pointer is within the dial scale endpoints, disconnect the sender wire from the sender. Keep the sender installed in its proper location. Allow the sender wire to hang freely.



CAUTION

The sender lead must be disconnected for this test. Failure to heed this caution will result in severe damage to the sender.

Momentarily apply power to the gauge. The pointer should move off scale to the extreme left. Remove power from the gauge.

- e. **Grounded Sender Test** — Attach the sender wire from the gauge to an established chassis ground. Momentarily apply power. The pointer should move to the far right of the scale. Remove power. If the gauge fails this test, replace the gauge and retest. Go to step 3A above.
4. If the pointer jumps rapidly, overshoots or oscillates around the rest position, the sender connection contact is intermittent. Trace the sender wiring and verify that the gauge and sender connections are secure. If connections are tight and in good condition, replace the gauge.

5. If the pointer stops, hesitates or shows any evidence of sticking, replace the gauge.
6. If the pointer moves extremely slowly, replace the gauge.
7. Remove power and attach sender wire to "S" terminal on back of the gauge. Check operation with system sender. If the gauge does not operate correctly, troubleshoot sender circuit as in step 3Bd.

1 Engine

Description

The Ottawa yard tractor is designed to utilize the benefits of a six-cylinder diesel engine of the type customarily found in fire engines, dump trucks and refuse haulers. Engine options are provided for OFF-HIGHWAY and DOT/EPA certified applications with a choice of power ratings available from several engine manufacturers.

For service and maintenance information, consult the manuals included with your vehicle, contact the Kalmar dealer or the manufacturer of the component installed in your vehicle.

1.1 Controls and instruments

1.1.3 Oil Gauge

Diagnosis

Oil Pressure Gauge Components

- Cab Accessory Circuit Breaker
- Headlight Switch
- Ignition Switch
- Oil Pressure Gauge
- Oil Pressure Sending Unit
- Panel Dimmer Switch (Optional)

Oil Pressure Gauge Circuit Diagnosis

Observation	Cause	Action
Zero reading	Circuit breaker open	Reset. Repair short as needed. Replace circuit breaker as needed.
	Open circuit, loose connection	Test. Repair as needed.
	Defective gauge	Test. Replace as needed.
	Defective alternator	Test. Replace as needed.
Inaccurate gauge	Defective gauge	Test. Replace as needed.
Does not return to zero with ignition off	Defective gauge	Test. Replace as needed.

1.1.7 Fuel Gauge

Diagnosis

Fuel Gauge Components

- Cab Accessory Circuit Breaker
- Fuel Level Gauge
- Fuel Level Sending Unit
- Headlight Switch
- Ignition Switch
- Panel Dimmer Switch (Optional)

Fuel Gauge Circuit Diagnosis

Observation	Cause	Action
Zero reading	Circuit breaker open	Reset. Repair short as needed. Replace circuit breaker as needed.
	Open circuit, loose connection	Test. Repair as needed.
	Defective gauge	Test. Replace as needed.

Observation	Cause	Action
	Defective alternator	Test. Replace as needed.
Inaccurate gauge	Defective gauge	Test. Replace as needed.
Does not return to zero with ignition off	Defective gauge	Test. Replace as needed.

1.1.13 Coolant Gauge

Diagnosis

Coolant Gauge Components

- Cab Accessory Circuit Breaker
- Coolant Temperature Gauge
- Coolant Temperature Sending Unit
- Headlight Switch
- Ignition Switch
- Panel Dimmer Switch (Optional)

Coolant Temperature Circuit Diagnosis

Observation	Cause	Action
Zero reading	Circuit breaker open	Reset. Repair short as needed. Replace circuit breaker as needed.
	Open circuit, loose connection	Test. Repair as needed.
	Defective gauge	Test. Replace as needed.
	Defective alternator	Test. Replace as needed.
Inaccurate gauge	Defective gauge	Test. Replace as needed.
Does not return to zero with ignition off	Defective gauge	Test. Replace as needed.

1.2 Fuel System

1.2.1 Fuel tank

Description

Brackets bolted to the rail hold the 24-inch (610 mm) diameter, 50-gallon (190 liter) fuel tank. Two-inch (51 mm) wide straps secure the tank to the two mounting brackets. Rubber strap liners protect against chafing between the straps and the tank. The manufacturer's name plate is fastened to the side of the tank where it can easily be seen.



Fuel Tank and Fittings

WARNING

Diesel fuel is combustible. Do NOT smoke and do NOT use an open flame while fueling.

Failure to heed this warning may result in serious personal injury and property damage.

1.2.6 Sensor, fuel level

Description

The tank is fitted with a fuel level sending unit and a vent plug. A float riding on the surface of the fuel causes current changes which are transmitted via the sending unit to the instrument panel gauge.

1.2.8 Pipes and hoses

Description

Fuel hoses are constructed of rubber and braided steel wire.

1.11 Start / stop

Diagnosis (Starting and Charging Diagnosis)

Components

- Alternator
- Batteries
- Ignition Switch
- Starter
- Starter Relay
- Starter Solenoid

Starting and Charging Circuit Diagnosis

Observation	Cause	Action
Battery charge low/discharged	Defective wiring	Inspect connections and wires. Test circuits. Repair or replace as needed.
	Defective battery	Replace as needed.
	Defective alternator	Repair or replace as needed.
Engine does not crank	Battery charge low/discharged	See above.
	Defective wiring	Inspect connections and wires. Test circuits. Repair or replace as needed.
	Defective relay	Replace.
	Defective solenoid	Replace.
	Defective starter	Replace.

2 Transmission

Description

The standard transmission is an automatic Allison, RDS series. For service and maintenance information, consult the manuals included with your vehicle, contact the Kalmar dealer or the manufacturer of the component installed in your vehicle.

3 Driveline / Axle

Description

An Ottawa tractor will be equipped with one of several manufacturer's rear axles. Special features, such as a locking or a "No-Spin" differential, are optional. Contact your Kalmar dealer if you do not know whether your vehicle contains these features.

For service and maintenance information, consult the manuals included with your vehicle, contact the Kalmar dealer or the manufacturer of the component installed in your vehicle.

4 Brakes

4.1 Controls and instruments

4.1.1 Foot Pedal (Treadle Valve)

Description

This foot-actuated valve is actually two valves that operate in quick sequence. It is connected in the front and rear brake circuitry so that the rear brakes begin to act before the front brakes when the operator steps on the pedal. When air pressure is correct in both circuits, the second stage is driven via air pressure by the first stage. If air is lost to the first stage, the second stage is driven mechanically by the first stage.

4.1.9 Air Control Valves

Description

There are two air control valves on the instrument panel. The tractor parking brake has a yellow knob. The trailer air supply knob is red.

Normal vehicle operation with trailer in tow requires that both knobs be depressed. All braking control then transfers to the foot pedal.

Operating in **bobtail** mode requires that the red knob be pulled out (stop trailer air supply) and the yellow knob be depressed (release tractor parking brakes).



Instrument Panel 4 — Trailer Air Supply and Tractor Parking Control Knobs

4.3 Brake System

Description

Major components of the air brake system include the following items.

- Air Compressor and Governor
- Foot Pedal (Treadle Valve)
- Air Control Valves
- Air Reservoirs (Air Storage)
- Air Dryer (Optional)
- Tractor Protection Valves
- Proportioning (Bobtail) Valve (Optional)
- Quick Release Valves
- Double (Two-Way) Check Valves
- Brake Chambers and Parking Brakes
- Slack Adjusters
- Foundation (Wheel) Brakes
- Trailer Brake Air Lines
- Stop Light Switch

Within the system are two separate air distribution circuits. These operate the rear (primary) and front (secondary) foundation brakes. Air flow within the two circuits is controlled through a series of valves which supply or release air to the chambers in response to the driver's command. The parking brakes are spring-actuated, but compressed air is required to release them.

A buzzer and an indicator light warn of low pressure in the system when pressure falls below 70 PSI. The air pressure gauge reflects the actual system pressure.

4.3.1 Air Compressor and Governor

Description

Pressure is supplied by a reciprocating piston-type compressor mounted on the engine. The compressor shares engine lubrication and coolant systems.

Running continuously, the compressor requires a governor to maintain the necessary system pressure. The governor is mounted on the compressor. Operating in conjunction with an unloading valve, the governor directs air into the reservoirs or out the exhaust port.

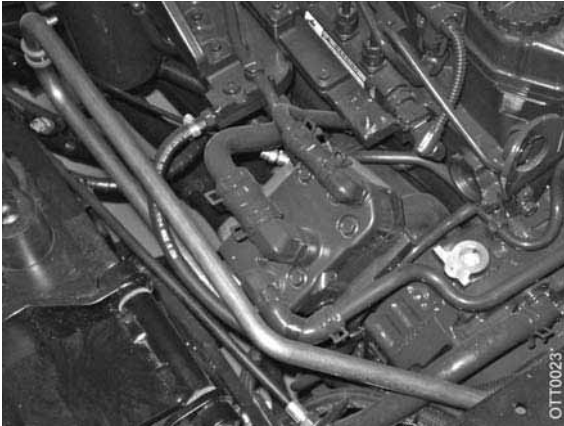

Air Compressor Governor

4.3.4 Air Reservoir

Description

The air reservoirs maintain a sufficient quantity of air under pressure to sustain several applications of the brakes. Standard vehicles have two reservoirs. Vehicles with a split brake system (DOT/EPA approved vehicles) have three air reservoirs.

In the *three-reservoir* system, one serves as the primary, sometimes called the *wet tank*. It supplies air to the other two reservoirs independently. A pressure relief valve in the primary tank protects the system from excessive pressure.

One of the two secondary reservoirs supplies air to the front brakes and the other to the rear brakes. Check valves prevent air from returning to the compressor when it is not running. This arrangement allows one set of brakes to operate in the event the other should fail.

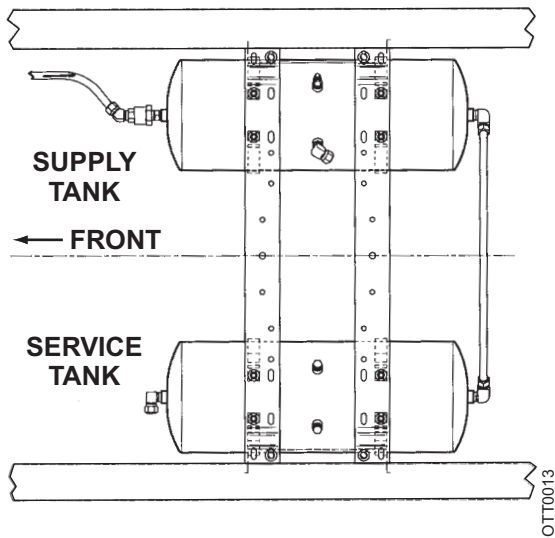

Air Storage Tanks — Two-Reservoir System

In the *two-reservoir* system, compressed air goes to the supply tank where it passes through to the service tank and from there to the rest of the system. A pressure relief valve in the supply tank protects the system from excessive pressure.

Each tank has its own drain valve to release water and oil that may have accumulated in the tank during operation.

System pressure is monitored by a low pressure sensor that communicates with an indicator light mounted in the instrument panel and a buzzer mounted on an electrical relay panel on the cross member below the steering column. The indicator and buzzer are activated while the system pressure is below 70 PSI.

4.3.9 Stop Light Switch

Description

This is an air-actuated switch that causes the stop lights to illuminate when system air pressure increases to 5 PSI after depressing the foot pedal.

4.3.10 Brakes

Description

Brake Chambers and Parking Brakes — In the front are two single chamber units at the wheel ends. These operate the foundation brakes described below.

In the rear are two dual chamber units at the wheel ends. These operate both the foundation brakes and the parking brakes. When there are dual rear axles, brake chambers are typically mounted on the forward axle, but are sometimes supplied on both axles.

The brake chamber is designed to move the shoes against the drums using air pressure. Air pressure is released into the chamber by the foot pedal. Push rods change the air pressure into mechanical action to rotate the brake cam shafts. The push rods in the brake chambers provide a 2.25–2.50-inch (57–64 mm) range of stroke length.

The second chamber in the dual chamber unit uses the air pressure to keep a powerful spring compressed. This spring, attached to the push rod, provides the parking brake action.

When system air pressure falls below 43 PSI, the springs activate the push rods and apply the foundation brakes. When system air pressure rises above the set point, it overcomes the spring pressure and releases the brakes.

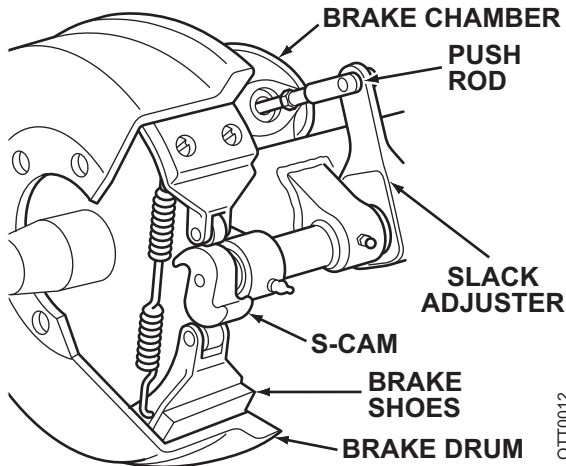

Slack Adjuster Diagram

OTT0012

For service, the springs can be released manually if the engine cannot be started, or if air pressure cannot be restored to the system.

Slack Adjusters — Slack adjusters change the distance the brake shoes have to travel to contact the drum. During each application of the brakes, automatic adjusters detect the rotation of the brake cam shaft. They retain the setting at the point where the lining contacts the drum. This setting changes as the drum and linings wear.

Manual adjusters include a worm gear and an adjusting screw that provide the means to reset the clearance between the shoe and the drum. Manual adjustments have to be made when the vehicle is stationary and the adjusting screws are accessible.

Foundation (Wheel) Brakes — The foundation brakes consist of brake drums on the wheels and shoes lined with friction material attached to the axles. Actuated via cams rotated by push rods in the brake chambers, the shoes are pressed against the drums. Air pressure controlled by the foot pedal supplies the force necessary to stop the wheels from rotating.

4.3.11 Trailer Brake Air Lines

Description

Coiled service (blue) and supply (red) lines provide trailer braking controls. Both air lines must be connected in order to release the trailer parking brakes.



Trailer Electrical Connector and Brake Hoses

OTT0021

4.3.14 Anti-lock Brake System (Optional)

Description

Some vehicles will be equipped with an anti-lock brake system (ABS). This system prevents the wheels from completely stopping rotation (locking up) when the brakes are applied. The benefit of this is to overcome the tendency of a vehicle to lose steering control during emergency braking.

Toothed rings and sensors at the wheel ends work together to reflect individual wheel speeds. The sensors send the data to the EC-60 electronic control unit mounted in the left front wheel well.

The anti-lock modulator valve in conjunction with the EC-60 electronic control unit responds to the signals from the sensors to control the air pressure at the individual wheel brakes. As a wheel's speed approaches 0 rpm (locked up), air pressure to that brake is repeatedly released and reapplied. The process continues until all wheel speeds are equal. Braking action then continues evenly until the foot pedal is released.

There is an indicator light on the instrument panel to warn when the system malfunctions. This system can also check the trailer for a proper operating system. A malfunction in the trailer system actuates a separate light on the instrument panel.

Diagnosis and fault code clearing are available through the EC-60 electronic control unit if so equipped. There is a diagnostic connection behind the grille opening in the front bumper. The connection can be used by a laptop with appropriate software or a handheld Bendix RDU diagnostic tool.

4.3.15 Automatic Traction Control (Optional)

Description

Some vehicles that are equipped with ABS may also be equipped with full-time automatic traction control (ATC). The ATC indicator lamp blinks when ATC is working.

ATC uses the ABS wheel sensors. It compares front wheel speed to rear wheel speed and left rear wheel speed to right rear wheel speed. When a set ratio is exceeded, ATC applies the rear brakes to the appropriate wheel end.

ATC operates only at speeds less than 25–30 miles per hour (40–48 kilometers per hour). At higher speeds, vehicle reaction to a sudden application of the brakes on one side may cause loss of driver control.

4.3.16 Manually Releasing Tractor Spring Brakes (Caging)

Description

When air pressure in the system drops below approximately 43 PSI, the spring parking brakes will apply automatically. To release the spring brakes, the air pressure must be returned to 70 PSI. If the system cannot be recharged and the vehicle must be moved, the spring parking brakes can be released manually (caged).

To release the spring brakes, the actual spring in the brake canisters must be mechanically compressed. A release stud, or spring caging tool, must be used to manually compress the brake chamber.

DANGER

Never manually release (cage) the spring brakes before the wheels are properly blocked. If the wheels are not properly blocked before releasing the spring brakes, the vehicle may move unexpectedly. This could result in serious injury or death.

The following steps can be used to release the standard brake chambers used on most Kalmar tractors. If your vehicle is equipped with other optional brake chambers, refer to that manufacturer's operation or service manual.



Internal Caging Tool

- 1 Shut the engine off and remove the key.
- 2 **BLOCK ALL** wheels front and rear to prevent the vehicle from rolling forward and backward.
- 3 Determine whether the chamber has an internal or external caging tool (see figures). Proceed to step 4 with an external-mounted tool. See step 8 for internal types.
- 4 Remove the access plug from the brake canister.
- 5 Insert the caging tool into the access hole, "T" end first.
- 6 Turn the caging tool 1/4 turn to engage with the slot on the pressure plate.
- 7 Try to pull the caging tool out; it should not pull out. If it does, repeat steps 5 and 6.

- 8 Thread the nut and washer down onto the threaded end of the caging tool all the way to the canister.
- 9 Tighten the nut until the threaded portion of the release tool is out. It should extend approximately 3 inches (76.2 mm) out of the nut.

3 inches (76.2 mm) — Type 2430 and 3030 Chambers

4 inches (101.6 mm) — Type 3036 and 3636 Chambers

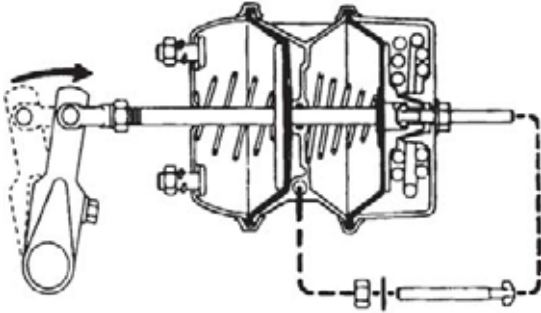

! CAUTION

Never use an impact wrench to tighten the nut onto the release bolt. Never exceed the above lengths and never exceed 50 ft. lbs. (67.79 Nm) of torque on the release nut or the chamber may be damaged.

External Caging Tool

4.9 Diagnosis (Mechanical)

Brakes

Components

- Brake Drums
- Brake Shoes

Brakes — Mechanical Diagnosis

Observation	Cause	Action
Pulls to one side	Brakes out of adjustment Poor front end alignment Unequal tire pressure or tread Uneven vehicle loading Loose front wheel bearings	Adjust slack adjusters. Inspect and repair as needed. Inspect. Repair or replace as needed. Inspect. Redistribute load as needed. Inspect. Repair or replace as needed.
Insufficient braking power	Low air system pressure Poor adjustment, poor lubrication or worn brake linings Defective components (e.g., slack adjusters, push rods, cams) Air line(s) restricted	Inspect for leaks. Repair or replace as necessary. Inspect. Adjust, lubricate and repair as needed. Inspect. Repair or replace as needed. Inspect. Repair or replace as needed.
Slow application	Poor adjustment or poor lubrication Air line(s) restricted Treadle valve leaking Brake chamber leaking Spring brake chamber leaking	Inspect. Adjust or lubricate as needed. Inspect. Repair or replace as needed. Inspect. Repair or replace as needed. Inspect. Repair or replace as needed. Inspect. Repair or replace as needed.

Observation	Cause	Action
Slow release	<p>Treadle valve return slowed by dirt and grime</p> <p>Poor adjustment or poor lubrication</p> <p>Air line(s) restricted</p> <p>Valve exhaust ports (e.g., treadle, quick release, relay) plugged</p>	<p>Clean and lubricate as needed.</p> <p>Inspect. Adjust or lubricate as needed.</p> <p>Inspect. Repair or replace as needed.</p> <p>Inspect. Repair or replace as needed.</p>
Service brakes do not release	<p>Broken or weak shoe or chamber spring</p> <p>Treadle valve return slowed by dirt and grime</p> <p>Air line(s) restricted</p> <p>Valve exhaust ports (e.g., treadle, quick release, relay) plugged</p>	<p>Inspect. Repair or replace as needed.</p> <p>Clean and lubricate as needed.</p> <p>Inspect. Repair or replace as needed.</p> <p>Inspect. Repair or replace as needed.</p>
Brakes grab	<p>Grease or oil on linings</p> <p>Drum out of round</p> <p>Defective valves</p> <p>Actuating linkages (e.g., slack adjusters, push rods) bind</p>	<p>Determine source of grease or oil. Repair as needed. Clean drums and replace shoes.</p> <p>Inspect. Repair or replace as needed.</p> <p>Inspect. Repair or replace as needed.</p> <p>Inspect. Repair or replace as needed.</p>
Uneven braking	<p>Poor adjustment or poor lubrication</p> <p>Grease or oil on linings</p> <p>Broken diaphragm or return spring</p> <p>Drum out of round</p> <p>Brake chamber diaphragm leaking</p>	<p>Inspect. Adjust or lubricate as needed.</p> <p>Determine source of grease or oil. Repair as needed. Clean drums and replace shoes.</p> <p>Inspect. Repair or replace as needed.</p> <p>Inspect. Repair or replace as needed.</p> <p>Inspect. Repair or replace as needed.</p>

Observation	Cause	Action
No pressure buildup Low air pressure warning Pressure drops quickly: engine stopped, brakes applied Pressure drops: engine stopped, brakes applied Pressure does not reach normal Pressure builds too slowly Pressure too high No brakes		Refer to Brake Air System Diagnosis table.

5 Steering

5.2 Servo steering system

Description (Power Steering Components)

The standard power steering system uses an integral power steering gear and the transmission-mounted hydraulic pump. The system operates on fluid drawn from the common reservoir shared with the boom and cab tilt systems.

Integral Power Steering Gear — When the steering wheel is turned, force is transmitted from the steering wheel to the steering gear input shaft. A torsion bar pinned at one end to the input shaft and at the other end to the worm shaft, turns with the input shaft and exerts a rotational force on the worm shaft. In response to this rotational force, the worm shaft, acting through the recirculating ball mechanism, moves the rack piston axially through the gear-housing cylinder bore.

The rack piston's axial movement is resisted by its engagement to the sector shaft, which is connected by linkage to the steered wheels. Because of this resistance, the input shaft actuates the control valve and twists the torsion bar. Pressurized fluid directed by the control valve, assists in moving the rack piston axially through the cylinder bore. The rack piston then turns the sector shaft to steer the vehicle.

Description (Optional Hydrostatic Steering Components)

Hydrostatic steering consists of an orbital control valve, a hydraulic pump (either engine mounted or mounted via a PTO on the transmission), steering cylinders, a reservoir, and fluid lines. The orbital control valve has a steering wheel attached; the steering cylinders are attached to the front axle and connected to the steered wheels.

The orbital control valve is made up of two sections: the control valve section and the metering section. The control valve section directs fluid to and from the metering section and the steering cylinders, and regulates the pressure to the steering cylinders. The control valve section is made up of a mechanically actuated spool valve and pressure chambers to provide circuit isolation. The metering section controls the amount of fluid to the steering cylinders while maintaining the relationship between the steering wheel and the steered wheels. This section can also act as a manual pump providing manual steering

in the event of an inoperable hydraulic pump. The metering section consists of a rotor that orbits within a fixed stator to force oil through the section, and a commutator to channel the fluid to the valve section.

5.3 Diagnosis Power Steering)

Power Steering

Components

- Power Steering Gear
- Power Steering Pump
- Reservoir

The following guide covers symptoms that may be remedied by adjustments outside of the steering gear. For symptoms indicating problems within the steering gear, consult the manufacturer's service manuals.

Power Steering Diagnosis

Observation	Cause	Action
Hard steering	Overloaded axle	Review GAWR specifications. Reload as needed.
	Underinflated tires	Inflate correctly.
	Front end misaligned	Align front end.
	Worn linkages	Replace as needed.
	Damaged king pins or tie rods	Repair or replace as needed.
	Steering column binding	Repair as needed.
	Weak fluid flow rate	Review manufacturer's manual or replace pump.
Wheel cuts restricted	Axle stop setting	Reset.
Steering-to-frame interference	Drag link adjustment	Reset.
	Pitman arm adjustment	Reset.
Inconsistent steering pressure	Air in system	Bleed system.
	Low fluid level	Add fluid as needed.

5.4 Diagnosis (Hydrostatic steering)

Hydrostatic Steering

Hydrostatic steering is optional.

Components

- Orbital Control Valve
- Power Steering Pump
- Steering Cylinders
- Reservoir

The following guide covers symptoms that may be remedied by adjustments outside the orbital control valve. For symptoms indicating problems within the orbital control valve, consult the manufacturer's service manuals.

Hydrostatic Steering Diagnosis

Observation	Cause	Action
Hard steering	Overloaded axle	Review GAWR specifications. Re-load as needed.
	Underinflated tires	Inflate correctly.
	Front end misaligned	Align front end.
	Worn linkages	Replace as needed.
	Damaged king pins or cylinder connections	Repair or replace as needed.
	Steering column binding	Repair as needed.
	Weak fluid flow rate	Review the manufacturer's manual and/or replace pump.
	Leaking fluid hoses	Repair or replace as needed.
Wheel cuts restricted	Axle stop setting incorrect	Reset.
Inconsistent steering pressure	Air in system	Bleed system.
	Low fluid level	Add fluid as needed.
	Leaking fluid hoses	Repair or replace as needed.

6 Suspension

Description (Vehicle suspension including Otto-ride)

The front suspension consists of shackled leaf springs. There are 10 steel leaves on the driver's side and nine on the other side. Rubber blocks mounted on each axle reduce the shock of bottoming out.

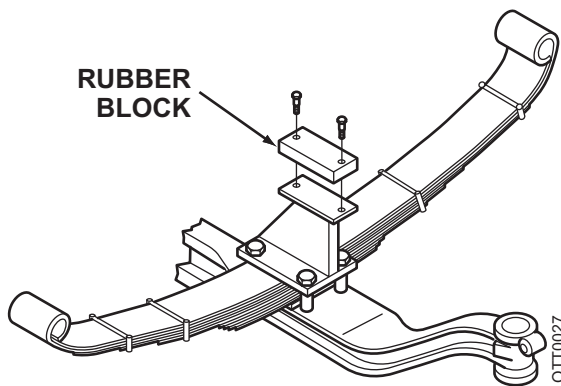

Leaf Spring Suspension

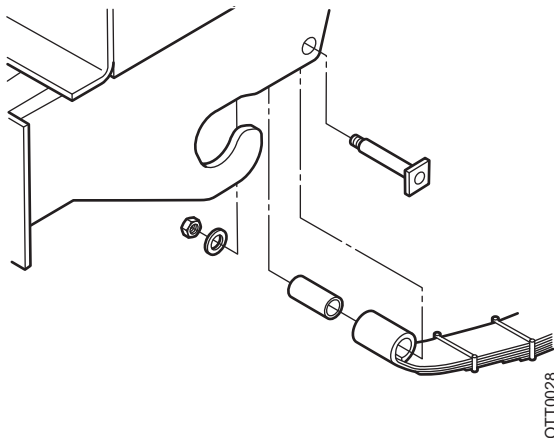

Front Spring Anchor and Tow Hook

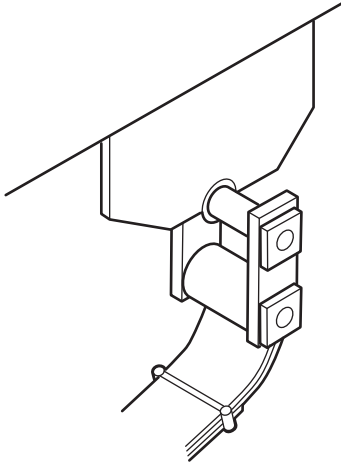

Rear Spring Hanger

OTT0029

Eyes at the rear of the front springs connect to the rear spring anchor via shackles and pins. Bushings on each pin help to reduce friction.

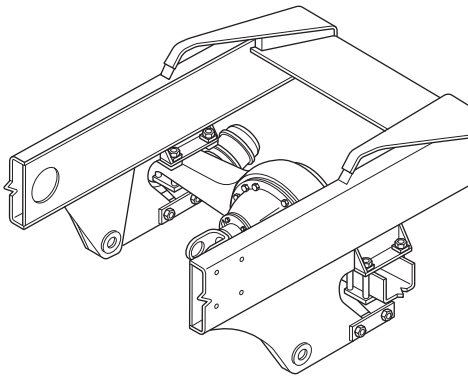

Rear Axle Attachment

The standard vehicle is equipped with a rear axle (or axles) attached directly to the frame rails without any suspension system. Axle housings are rigidly attached to the frame, captured by means of weldments mounted inside and outside of each rail.

Otto-Ride — Optionally, a system can be installed to soften the ride at the rear axle. This suspension frees the axle housing from rigid attachment to the frame rails.

The boom lift cylinders are attached to the forward side of the axle housing instead of the rails. To resist axle housing rollover and limit misalignment, a special frame is attached between the rails above and behind the axle housing.

A hollow cylindrical rubber cushion mounted on this special frame limits the axle housing rollover. Sideways motion is limited by a torque rod attached to the special frame and the right side rail.

6.2 Front Springs and Pins

Repair (Springs and Pins Removal)

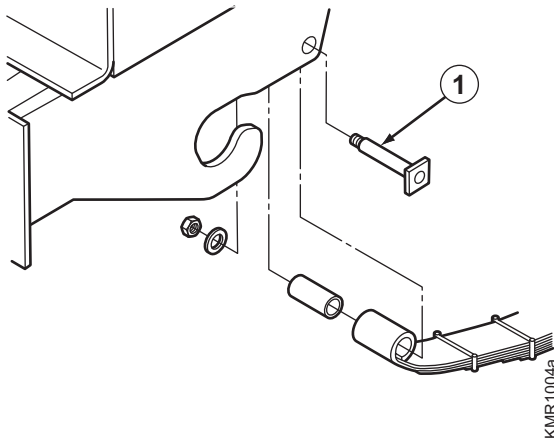

1. Park the vehicle on level ground and chock the rear wheels.
2. Raise the front of the vehicle high enough to relieve all tension on the front springs while allowing the front wheels to remain in contact with the ground. Place jack stands under the frame to support the front of the vehicle in the raised position.
3. With the vehicle raised, chock the front wheels to prevent the axle from moving as the springs are removed in the following steps.
4. Remove the nut and washer from the pin (1) at the front spring eye and the nuts and washers from the shackle pins (2) at the rear of the spring.

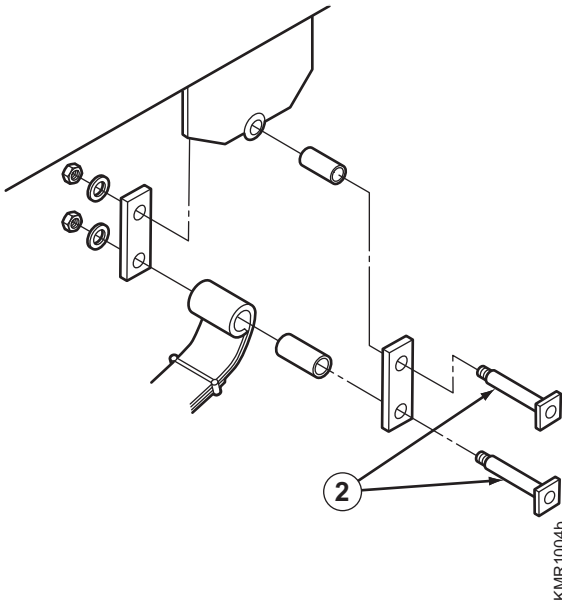

1. Using a suitable pry bar, remove the pins (1, 2) securing the front spring to the frame brackets.
2. Support the spring and remove the nuts, washers and bolts (3) securing the bump stop, spring assembly and spacer to the front axle.
3. Remove the bump stop, spring assembly and spacer.
4. Repeat steps 4 through 7 to remove the spring assembly at the opposite side.

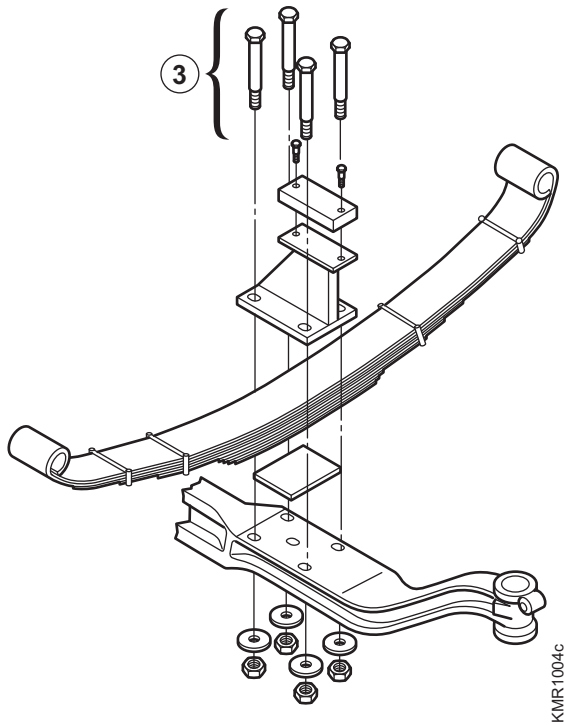

Repair (Springs and Pins Installation)

1. Place the spacer, spring assembly and bump stop in position on the front axle and install the mounting bolts (3), washers and nuts to secure the assembly to the axle. Tighten the bolts and nuts to specification.
2. Align the spring eye with the front frame bracket and install the pin (1), washer and nut. Tighten the nut to specification.



CAUTION

Use care to avoid damage to the spring pins as they are being installed.

3. Install the hangers, pins (2), washers and nuts to secure the rear of the spring to the frame bracket. Tighten the nuts to specification.
4. Repeat steps 1 through 3 to install the spring assembly at the opposite side.
5. Remove the jack stands and lower the vehicle to the ground.

NOTE

After 50 hours of operation — *Check and retighten the bolts, if necessary.*

7 Load Handling

7.2 Lift and lower

Description (Boom Components)

1. Boom Pivot
2. Boom
3. Boom Lift Cylinder Pivots
4. Fifth-Wheel Pivot
5. Fifth-Wheel Plate

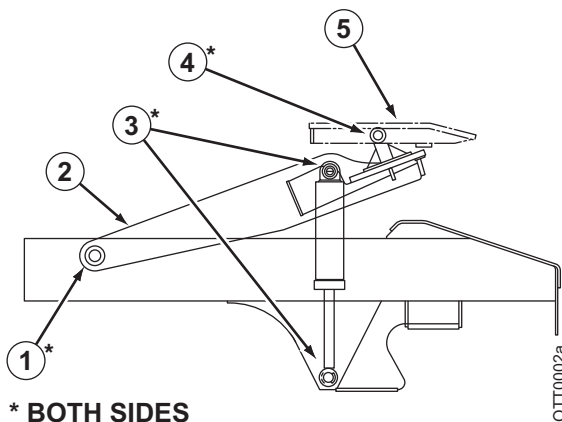

* BOTH SIDES

Elevated Boom with Fifth Wheel

The standard hydraulically operated boom is the basis for the fifth-wheel lifting system. The forward end of the boom assembly is attached to the frame at a pivot point behind the cab. Mounted at the rear of the boom is the fifth wheel which is raised and lowered through the action of two hydraulic cylinders installed between the boom and frame weldments just forward of the rear axle. Power to operate the cylinders is supplied by the hydraulic pump mounted on the transmission.

7.2.1 Hydraulic pump

Description

On a standard chassis, the hydraulic pump is a fixed, positive displacement gear type. The pump is rated at 10 gallons (38 liter) per minute at high idle (approximately 1200 RPM). A relief valve in the lift control valve limits operating pressure.

7.2.3 Control Valve

Description

The valve housing is a one-piece mono-block casting. The "A" and "B" work ports are precision machined and threaded to accept the "T" and "P" pressure (inlet) passages. The valve is open-centered and closed port. Incorporated in the valve assembly are load check valves and a relief cartridge with a maximum relief pressure of 2000 PSI (138 bar) for the 5-inch (127 mm) diameter cylinders. The valve is actuated remotely from the cab by the boom lift control lever. The boom lift control lever is attached to a control cable that pulls and pushes the control valve spool to the desired positions.

7.2.1 Boom lift cylinders

Description

The standard configuration utilizes two 5-inch (127 mm) diameter lift cylinders with a capacity of 60,000 pounds (27,216 kg) and a lifting height of 17 inches (432 mm). The cylinders are double acting in that they are hydraulically powered up and down. Restrictor fittings are threaded into the base end work ports to better control downward (lowering) speed.

7.11 Diagnosis (Boom)

Diagnosis

Components

- Control Valve
- Filter
- Boom Lift Cylinders
- Hydraulic Pump
- Hydraulic Relief Valve
- Reservoir
- Wet Line Kit Connection

Maximum Pressure — Hydraulic Relief Valve

Vehicle	Maximum Pressure
All Ottawa 4x2 and 6x4 tractors with 5-inch cylinders	2000 PSI (138 bar)



WARNING

Do NOT feel for leaks. Hydraulic fluid under high pressure may have knife-like characteristics. Failure to heed this warning could result in severe personal injury.

Boom Diagnosis

Observation	Cause	Action
Cylinders leak down	Damaged seals or cylinder wall Worn control valve	Replace cylinder. Optional: Install seal kits. Replace. Optional: Install seal kits.
Drops slightly, momentarily before lifting	Load check seat or control valve spring malfunction	Clean or replace as needed.
Lifts slowly	Pump inlet restricted Worn pump Internal leakage in control valve Internal leakage in cylinders External leakage from hoses	Remove restriction. Replace. Replace. Optional: Install seal kits. Replace cylinder. Optional: Install seal kits. Replace leaking hose.

Observation	Cause	Action
	Valve actuating cable/lever not centered	Adjust. Unbind. Lubricate as needed.
Stalls under load	Low fluid level Low relief valve setting Extraordinary internal leakage External leakage from hoses Extraordinary pump wear	Add fluid as needed. Adjust or replace. Test circuits to isolate point of leakage. Replace leaking hose. Replace.
Inoperative	Seized or damaged lever or control cable Extreme internal leakage	Repair as needed. Test circuits to isolate point of leakage.
Jerky, erratic movement	External leakage from hoses Air in system	Replace leaking hose. Inspect fittings and seals. Replace as needed.

8 Control System

Introduction - General Information

Not available.

9 Frame, body, cab and accessories

9.1 Controls and Instruments

Description

Gauges, controls and indicators appear in five panels in front and to the side of the driver as shown below. Panels 1 and 2 mount in front of the steering wheel. Panel 3 is mounted in the transition between the cab instrument panel and the top of the bulkhead assembly. Panels 4 and 5 are mounted on top of the bulkhead assembly.

Panels 1 and 2 are backlit when the headlights are on. The dimmer switch is optional.



Instrument Panel Surround



Instrument Panel 1

Panel 1 — displays the following gauges, controls and indicator lights along with an air diffuser for the heating and optional air conditioning system.

- Gauges and Controls
 - Fuel
 - Oil Pressure
 - Water Temperature
 - Tachometer (Optional)
 - Speedometer
 - Headlight Switch
 - Panel Dimmer Switch (Optional)



Instrument Panel 2

- Indicator Lights
 - Wait to Start
 - Service Soon
 - Check Engine
 - Stop Engine
 - Left Turn
 - ABS (DOT/EPA approved tractors)
 - Diesel Particulate Filter (DOT/EPA approved tractors)

Panel 2 — displays the following gauges, controls and indicator lights.

- Gauges and Controls
 - Hourmeter
 - Voltmeter (standard) or Ammeter (optional)
 - HVAC Temperature Control
 - HVAC Directional Controls
 - Fan Speed Switch (HVAC)
 - AC On/Off Switch (Optional)
 - Flood Light Switch
 - Ignition Key Switch
 - Windshield Wiper Switch
 - Windshield Washer Switch (Optional)
- Indicator Lights
 - High Beam
 - Right Turn
 - Low Brake Air Pressure (lit below 70 PSI)
 - Check Trans

Panel 3 — may be blank, but it is available for additional gauges, controls and indicators as needed.

Panels 4 and 5 — display the following gauges and controls.



Instrument Panels 4 and 5

- Air Gauge
- Second Air Gauge (with split air system)
- Tractor Park Control
- Trailer Air Supply Control
- Transmission Shifter
- Fifth-Wheel and Boom Control
- Fifth-Wheel Latch Control

Electroluminescent (EL) displays for the transmission shifter and the fifth-wheel control glow when the ignition switch is in the **On** position.

Each of the panels has room to add additional gauges and indicator lights as needed.

9.1.36 Low Air Warning

Diagnosis

The vehicle will be equipped with one of two air braking systems. Vehicles that travel on the roads are made to comply with the regulations in Federal Motor Vehicle Safety Standard (FMVSS) 121. Vehicles that do not travel on the roads have an equally reliable braking system.

An anti-lock braking system option may also be found on the vehicle.

Components

- Air Pressure Gauge
- Headlight Switch
- Low Air Buzzer
- Low Air Pressure Switch (Indicator)
- Low Air Warning Light
- Panel Dimmer Switch (Optional)

Low Air Warning Circuit Diagnosis

Observation	Cause	Action
Inoperative light and buzzer	Circuit breaker open	Reset. Replace as needed.
	Short circuit	Test. Repair as needed.
	Switch grounded	Test. Repair as needed.
	Defective air switch	Test. Repair as needed
	Defective assembly	Replace.
Inoperative buzzer, light OK	Open circuit	Test. Repair as needed.
	Defective buzzer	Replace.
Inoperative light, buzzer OK	Open circuit	Test. Repair as needed.
	Bulb burned out	Replace.

9.1.37 Ammeter

Diagnosis

Components

- Ammeter
- Headlight Switch
- Panel Dimmer Switch (Optional)
- Shunt

Ammeter Circuit Diagnosis

Observation	Cause	Action
Zero reading	Circuit breaker open	Reset. Repair short as needed. Replace circuit breaker as needed.
	Open circuit, loose connection	Test. Repair as needed.
	Defective gauge	Test. Replace as needed.
	Defective alternator	Test. Replace as needed.
Inaccurate gauge	Defective gauge	Test. Replace as needed.
Does not return to zero with ignition off	Defective gauge	Test. Replace as needed.

9.1.38 Hourmeter**Diagnosis****Components**

- Cab Accessory Fuse
- Hourmeter Gauge
- Ignition Switch
- Oil Pressure Switch

Hourmeter Circuit Diagnosis

Observation	Cause	Action
Inoperative	Circuit breaker open	Reset. Repair short as needed. Replace circuit breaker as needed.
	Defective wiring	Inspect connections and wires. Test circuits. Repair or replace as needed.
	Mislocated wiring	Inspect routing. Relocate wires or isolate terminals as needed.
	Defective oil pressure switch	Replace.
Intermittent	Defective wiring	Inspect wires for kinks and breaks. Repair or replace as needed.
	Mislocated wiring	Inspect routing. Relocate wires or isolate terminals as needed.
Runs unevenly, or fast or slow	Defective gauge	Replace.
	Defective oil pressure switch	Replace.

9.1.39 Speedometer

Diagnosis

The speedometer may include an optional connection to the pulse generator.

Components

- Cab Accessory Circuit Breaker
- Electronic Speedometer
- Headlight Switch
- Ignition Switch
- Panel Dimmer Switch (Optional)
- Pulse Generator (Optional)

Electronic Speedometer Circuit Diagnosis

Observation	Cause	Action
Panel lamp does not light	Circuit breaker open	Reset. Repair short as needed. Replace circuit breaker as needed.
	Loose lamp	Inspect lamp. Tighten or replace as needed.
	Burned out lamp	Inspect. Replace lamp (match system voltage).
	Defective wiring	Inspect connections and wires. Test circuits. Repair or replace as needed.
Inaccurate	Wrong DIP switch settings	Correct settings. Refer to the manual for specifications.
	Change of tire size, gear ratio or pulse source	Calculate pulses per mile (kilometer). Recalibrate speedometer as described in the DATCON manual.
	Defective wiring or sender	Inspect connections and wires. Test circuits. Inspect sender. Repair or replace as needed.
No reading	Circuit breaker open	Reset. Repair short as needed. Replace circuit breaker as needed.
	Mislocated wiring	Inspect routing. Relocate wires or isolate terminals as needed.
	Wrong DIP switch settings	Correct settings. Refer to the manual for specifications.
	Defective wiring	Inspect connections and wires. Test circuits. Repair or replace as needed.
	Pulse generator gears damaged	Replace gears.

Observation	Cause	Action
	Pulse generator inoperative	Replace generator.

9.1.40 Tachometer

Diagnosis

The tachometer is optional equipment.

Components

- Alternator
- Cab Accessory Circuit Breaker
- Headlight Switch
- Ignition Switch
- Panel Dimmer Switch (Optional)
- Tachometer

Tachometer Circuit Diagnosis

Observation	Cause	Action
Inoperative	Circuit breaker open Mislocated wiring Defective wiring	Reset. Repair short as needed. Replace circuit breaker as needed. Inspect routing. Relocate wires or isolate terminals as needed. Inspect connections and wires. Test circuits. Repair or replace as needed.
Intermittent	Mislocated wiring Defective wiring	Inspect routing. Relocate wires or isolate terminals as needed. Inspect connections and wires. Test circuits. Repair or replace as needed.
Inaccurate	Incorrect switch position	Refer to DATCON technical manual for correct configuration.

9.1.41 Voltmeter

Diagnosis

Components

- Cab Accessory Circuit Breaker
- Circuit Breaker
- Headlight Switch
- Ignition Switch
- Panel Dimmer Switch (Optional)
- Voltmeter

Voltmeter Circuit Diagnosis

Observation	Cause	Action
Panel lamp does not light	Loose lamp Burned out lamp Defective dimmer switch Circuit breaker open Defective wiring	Inspect lamp. Tighten or replace as needed. Replace lamp (match system voltage). Replace. Reset. Repair short as needed. Replace circuit breaker as needed. Inspect connections and wires. Test circuits. Repair or replace as needed.
Inaccurate	Defective gauge Defective wiring	Replace. Inspect connections and wires. Test circuits. Repair or replace as needed.
Inoperative	Circuit breaker open Defective gauge Defective wiring	Reset. Repair short as needed. Replace circuit breaker as needed. Replace. Inspect connections and wires. Test circuits. Repair or replace as needed.

9.3 Seating

Description

The tractor is fitted with a seat suspended on an air spring. The firmness of the ride is adjusted by changing the air pressure.

Seat height adjusts by changing the air pressure. A switch on the side of the seat controls the air pressure. Seat height is fixed by adjusting the tethers attached to each seat belt anchor.

The seat position can be adjusted fore and aft. The position of the seat cushion can be adjusted fore and aft independently of the seat position. A fore and aft isolator is included for snubbing undesirable chugging. This locking lever is mounted on the inside of the seat.



Driver's Seat — Side View

9.4 Heating, ventilation and air conditioning

Description

A heater is standard equipment. Air conditioning is optional.

Air diffusion is provided through ducts in the instrument panel near the side window and underneath the instrument panel near the center of the cab. Air flow can also be directed to the windshield and side windows. Instrument panel controls give the driver several air handling options including fan speed and cab air temperature.

9.5 Wiping and cleaning of windows

9.5.1 Windshield Wipers

Description

The windshield wiper is electrically driven. A rotary switch on the instrument panel also controls its operating speed. The Off parked position is at the counterclockwise limit. Maximum speed is at the clockwise limit.

Diagnosis

Components

- Circuit Breaker 8A
- Ignition Switch
- Wiper Motor
- Wiper Relay
- Wiper Switch

Windshield Wipers Circuit Diagnosis

Observation	Cause	Action
Inoperative	No power Linkage binding Defective switch Circuit breaker open Defective relay Defective wiring	Turn on ignition switch. Repair or replace as needed. Replace. Reset. Repair short as needed. Replace circuit breaker as needed. Replace. Inspect connections and wires. Test circuits. Repair or replace as needed.
Operate slowly	Linkage binding Low battery charge Defective wiring Defective motor	Repair or replace as needed. Recharge battery or replace as needed. Inspect connections and wires. Test circuits. Repair or replace as needed. Replace.
Operate at one speed	Defective switch Defective motor	Replace. Replace.
Do not park	Linkage binding	Repair or replace as needed.

Observation	Cause	Action
	Defective switch	Replace.
	Defective motor	Replace.

9.5.4 Windshield Washer

Description

A windshield washer system is an available option.

Diagnosis

The windshield washer is optional equipment.

Components

- Accessory Relay
- Ignition Switch
- Windshield Washer Motor
- Windshield Washer Switch

Windshield Washer Circuit Diagnosis

Observation	Cause	Action
Inoperative	No power	Turn on ignition switch.
	No fluid	Add fluid as needed.
	Hose or nozzle plugged	Clean as needed.
	Circuit breaker open	Reset. Repair short as needed. Replace circuit breaker as needed.
	Defective relay	Replace.
	Defective motor	Replace.
	Defective wiring	Inspect connections and wires. Test circuits. Repair or replace as needed.

9.6 Lighting system

Description

Kalmar provides a dome light, instrument panel lighting, headlights, marker lights and a trailer electrical connector with circuit breakers. A work area floodlight and a beacon are mounted on an upper rear corner of the cab.

9.6.1 Headlights

Diagnosis

Components

- Dimmer Switch
- Headlights
- Headlight Relay
- Headlight Switch
- Headlight Switch Circuit Breaker
- High-Beam Indicator Light

Headlight Circuit Diagnosis

Observation	Cause	Action
LH or RH headlight inoperative (high or low beam)	Defective lamp	Replace.
	Defective wiring	Inspect connections and wires. Test circuits. Repair or replace as needed.
Both headlights inoperative	Circuit breaker open	Reset. Repair short as needed. Replace circuit breaker as needed.
	Defective headlight switch	Replace.
	Defective relay	Replace.
	Defective wiring	Inspect connections and wires. Test circuits. Repair or replace as needed.
Inoperative headlight dimmer	Defective dimmer switch	Replace.
	Defective relay	Replace.

9.6.3 Clearance, Marker and Tail Lights

Diagnosis

Clearance and marker lights are standard only on vehicles assembled to meet FMVSS and CMVSS requirements.

Trailer marker and trailer tail light circuits are also controlled by the headlight switch via a trailer lights relay. A separate circuit breaker protects each trailer circuit.

Components

- Clearance Lights
- Headlight Switch
- Marker Lights (Trailer) (If Applicable)
- Marker Lights (Vehicle)
- Parking Light Circuit Breaker 10A
- Tail Lights (Trailer) (If Applicable)
- Tail Lights (Vehicle)
- Trailer Circuit Breaker 15A
- Trailer Lights Relay

Cab Clearance and Marker Light Circuit Diagnosis

Observation	Cause	Action
Individual light inoperative	Defective lamp Defective wiring	Replace. Inspect connections and wires. Test circuits. Repair or replace as needed.
All lights inoperative	Defective light switch Circuit breaker open Defective wiring	Replace. Reset. Repair short as needed. Replace circuit breaker as needed. Inspect connections and wires. Test circuits. Repair or replace as needed.

Trailer Clearance, Marker and Tail Light Circuit Diagnosis

Observation	Cause	Action
Individual light inoperative	Defective lamp Defective wiring	Replace. Inspect connections and wires. Test circuits. Repair or replace as needed.
All lights inoperative	Circuit breaker open Defective headlight switch	Reset. Repair short as needed. Replace circuit breaker as needed. Replace.

Observation	Cause	Action
	Defective relay Defective wiring	Replace. Inspect connections and wires. Test circuits. Repair or replace as needed.

9.6.4 Brake Lights

Diagnosis

Components

- Brake Light Switch
- Flasher Circuit Breaker 30A
- Stop/Tilt Circuit Breaker 20A
- Trailer Circuit Breakers 15A
- Turn Signal Switch
- Turn Signal Flasher
- Turn/Stop Light Lamps

Brake Lights Circuit Diagnosis

Observation	Cause	Action
Inoperative light	Defective lamp Defective turn signal switch Circuit breaker open Defective wiring	Replace. Replace. Reset. Repair short as needed. Replace circuit breaker as needed. Inspect connections and wires. Test circuits. Repair or replace as needed.
Inoperative brake lights	Defective lamp Defective brake light switch Circuit breaker open Defective wiring	Replace. Replace. Reset. Repair short as needed. Replace circuit breaker as needed. Inspect connections and wires. Test circuits. Repair or replace as needed.

9.6.5 Backup Light

Diagnosis

This circuit may contain an optional circuit breaker between the accessories relay and the flood light switch/backup flood relay.

Components

- Accessory Relay
- Backup Alarm
- Backup Relay
- Backup Light (rear of frame)
- Cab Flood Light Switch
- Circuit Breaker 15A
- Ignition Switch
- Reverse Switch

Backup Light Circuit Diagnosis

Observation	Cause	Action
Inoperative backup light	Defective lamp	Replace.
	Circuit breaker open	Reset. Repair short as needed. Replace circuit breaker as needed.
	Defective backup relay	Replace.
	Defective wiring	Inspect connections and wires. Test circuits. Repair or replace as needed.

Flood Light Circuit Diagnosis

Observation	Cause	Action
Inoperative	Defective lamp	Replace.
	Defective light switch	Replace.
	Circuit breaker open	Reset. Repair short as needed. Replace circuit breaker as needed.
	Defective relay	Replace.
	Defective wiring	Inspect connections and wires. Test circuits. Repair or replace as needed.

9.6.6 Turn Signal

Diagnosis

Components

- Brake Light Switch
- Flasher Circuit Breaker 30A
- Stop/Tilt Circuit Breaker 20A
- Trailer Circuit Breakers 15A
- Turn Signal Switch
- Turn Signal Flasher
- Turn/Stop Light Lamps

Turn Signal Circuit Diagnosis

Observation	Cause	Action
Inoperative light	Defective lamp Defective turn signal switch Circuit breaker open Defective wiring	Replace. Replace. Reset. Repair short as needed. Replace circuit breaker as needed. Inspect connections and wires. Test circuits. Repair or replace as needed.
Inoperative turn signal	Defective turn signal flasher Defective turn signal switch Circuit breaker open Defective wiring	Replace. Replace. Reset. Repair short as needed. Replace circuit breaker as needed. Inspect connections and wires. Test circuits. Repair or replace as needed.

9.6.8 Beacon Light

Diagnosis

This circuit may contain an optional circuit breaker between the accessories relay and the beacon light switch.

Components

- Accessory Relay
- Beacon Light
- Beacon Light Switch
- Ignition Switch

Beacon Light Circuit Diagnosis

Observation	Cause	Action
Inoperative	Defective beacon lamp	Replace.
	Defective switch	Replace.
	Circuit breaker open	Reset. Repair short as needed. Replace circuit breaker as needed.
	Defective wiring	Inspect connections and wires. Test circuits. Repair or replace as needed.

9.6.11 Dome Light

Diagnosis

Components

- Cab Accessory Circuit Breaker
- Dome Light

Dome Light Circuit Diagnosis

Observation	Cause	Action
Inoperative	Defective lamp	Replace.
	Defective dome light switch	Replace.
	Circuit breaker open	Reset. Repair short as needed. Replace circuit breaker as needed.
	Defective wiring	Inspect connections and wires. Test circuits. Repair or replace as needed.

9.6.12 Daytime Running Lights

Diagnosis

Daytime running lights are optional equipment.

Components

- Daytime Running Light Module
- Headlights
- Ignition Switch
- Module Fuse 10A

Daytime Running Lights Circuit Diagnosis

Observation	Cause	Action
Inoperative	Defective lamp	Replace.
	Defective fuse	Replace.
	Defective wiring	Inspect connections and wires. Test circuits. Repair or replace as needed.
	Defective daytime running light module	Replace.

9.6.14 Trailer Auxiliary Power

Diagnosis

Components

- Accessory Relay
- Ignition Switch
- Trailer Auxiliary Switch
- Trailer Circuit Breaker 15A
- Trailer Wiring Disconnect

Trailer Auxiliary Circuit Diagnosis

Observation	Cause	Action
No power at connector	Circuit breaker open	Reset. Repair short as needed. Replace circuit breaker as needed.
	Defective wiring	Inspect connections and wires. Test circuits. Repair or replace as needed.

9.6.15 Transmission Shifter/Fifth-Wheel Control and Panel Lighting

Diagnosis

Components

- Electroluminescent Lamps
- Incandescent Lamps
- Headlight Switch
- Inverter
- Parking Light Circuit Breaker 10A
- Panel Dimmer Switch

Electroluminescence

Electroluminescent (EL) lamps consist of two wafer-thin panels, one transparent and one opaque, that produce light when energized electrically. The panels are separated by an extremely narrow space. If a lamp is pinched so that the two panels come in contact, a short is created.

EL lamps require an inverter to change direct current to high cycle alternating current and increase the voltage. A shorted EL lamp will cause the inverter to shut down. To isolate the defective lamp, disconnect one lead to each lamp and reconnect one at a time. A good lamp lights when connected.

Transmission Shifter/Fifth-Wheel Control and Panel Lighting Circuit Diagnosis

Observation	Cause	Action
Inoperative light	Defective lamp	Replace.
	Defective dimmer switch	Replace.
	Circuit breaker open	Reset. Repair short as needed. Replace circuit breaker as needed.
	Defective wiring (or inverter)	Inspect connections and wires. Test circuits. Repair or replace as needed.

9.7 Signal system

9.7.1 Horn

Diagnosis

Components

- Horn
- Horn Button (Switch)
- Horn Circuit Breaker 15A
- Horn Relay

Horn Circuit Diagnosis

Observation	Cause	Action
Inoperative horn	Circuit breaker open	Reset. Repair short as needed. Replace circuit breaker as needed.
	Defective wiring	Inspect connections and wires. Test circuits. Repair or replace as needed.
	Defective horn button (switch)	Replace.
	Defective horn relay	Replace.
	Defective horn	Replace.
Diminished sound	Defective horn	Replace.
	Defective wiring	Inspect connections and wires. Test circuits. Repair or replace as needed.

9.7.2 Emergency Flasher

Diagnosis

Components

- Brake Light Switch
- Flasher Circuit Breaker 30A
- Stop/Tilt Circuit Breaker 20A
- Trailer Circuit Breakers 15A
- Turn Signal Switch
- Turn Signal Flasher
- Turn/Stop Light Lamps

Emergency Flasher Circuit Diagnosis

Observation	Cause	Action
Inoperative light	Defective lamp	Replace.

Observation	Cause	Action
	Defective turn signal switch	Replace.
	Circuit breaker open	Reset. Repair short as needed. Replace circuit breaker as needed.
	Defective wiring	Inspect connections and wires. Test circuits. Repair or replace as needed.

9.7.5 Backup Alarm

Diagnosis

This circuit may contain an optional circuit breaker between the accessories relay and the flood light switch/backup flood relay.

Components

- Accessory Relay
- Backup Alarm
- Backup Relay
- Backup Light (rear of frame)
- Cab Flood Light Switch
- Circuit Breaker 15A
- Ignition Switch
- Reverse Switch

Backup Alarm Circuit Diagnosis

Observation	Cause	Action
Inoperative alarm	Circuit breaker open	Reset. Repair short as needed. Replace circuit breaker as needed.
	Defective alarm	Replace.
	Defective backup relay	Replace.
	Defective wiring	Inspect connections and wires. Test circuits. Repair or replace as needed.

9.8 Maintenance and communication

9.8.1 Radio

Description

A radio is an available option.

Diagnosis

Components

- Accessory Relay
- Radio
- Radio Circuit Breaker 15A
- Speakers

Radio Circuit Diagnosis

Observation	Cause	Action
Inoperative radio	Circuit breaker open Defective relay Defective speakers Defective radio Defective wiring	Reset. Repair short as needed. Replace circuit breaker as needed. Replace. Repair or replace. Replace. Inspect connections and wires. Test circuits. Repair or replace as needed.
Poor performance	Defective antenna Defective speakers Defective radio Defective wiring	Repair or replace. Repair or replace. Replace. Inspect connections and wires. Test circuits. Repair or replace as needed.

9.9 Glass / window / mirrors

Description

Windows and Ventilation — The window in the driver's door moves up and down via a regulator handle on the door. A fixed side window ahead of the driver's door permits a full view on that side. A small ventilator door below this window provides fresh air inside at the driver's feet. A three-section window on the opposite wall allows an unobstructed view in that direction. The front and rear sections of this window slide horizontally as needed for ventilation.

9.9.5 Rear-view mirror

Description

Mirrors — Heated and heated/motorized outside rear view mirrors are optional equipment.

9.10 Construction and Suspension of Cab/Deck

9.10.1 Cab frame

Description

The cab four walls, roof and deck are constructed of 12-gauge galvanized steel for strength and rust protection. The walls are attached to the deck at four points by grade 5 bolts tightened to 120 ft. lb (163 Nm).

The deck provides the floor inside the cab and the walkway outside the cab. The floor and walkway are covered by matting with an abrasive surface for safer footing.

The instrument panel frame and the engine bulkhead inside the cab help make the assembly rigid.

Insulation panels line the roof and the engine side of the bulkhead.



Ottawa 4x2 — Rear View with Tilted Cab

9.10.2 Doors

Description

The rectangular driver's door is attached to the cab by a full-length piano-type hinge. The rear door slides and latches in open or closed position and gives quick access to the walkway and frame decking. The orientation of the door in its opening is adjustable. Refer to the repair procedures section for more information.

Repair (Rear Door Adjustment)

Use the following procedures to maintain smooth operation of the rear door.

1. With the door closed, adjust the upper rollers (A) to obtain a parallel, 3/8 inch (9.5 mm) gap between the right side of the door and the right side of the cab (1).

Adjust, as required, by installing shims between either roller assembly and the top of the door to rotate the door in position.

shim 53568426 = 1/16 inch (1.6 mm)

shim 53568427 = 1/32 inch (0.8 mm)

2. With the door closed, adjust the top of the door to obtain a 5/8 inch (16 mm) gap between the front of the door and the back of the door frame on the cab (2).

Adjust by loosening the roller attachment bolts (A) to move the door fore and aft.

3. With the door closed, adjust the rear door guide assembly (F) to obtain a 5/8 inch (16 mm) gap between the door and the cab at the bottom of the door (3).

When adjusting the guide assembly, adjust the guide blocks (D) using the guide blocks adjustment bolts (E), so they allow free, easy movement along the lower guide without an excess of play in both the open and closed positions.

Align the blocks (B) to the outer edges of the lower guide first and then adjust the inner blocks (C).

With the blocks adjusted, the guide assembly adjustment bolts (E) can be adjusted to achieve the 5/8 inch (16 mm) gap.

4. On doors with rubber bumpers (G), loosen the locknut and adjust so they are retracted as far as possible.

With the door closed, adjust the striker loop to the center of the latch opening (H).

5. Adjust the rubber bumpers (H) to compress the rubber 1/16 inch (1.6 mm) when the door is latched and tighten the locking nut.

6. Repeat steps 4 and 5 with the door in the closed position.

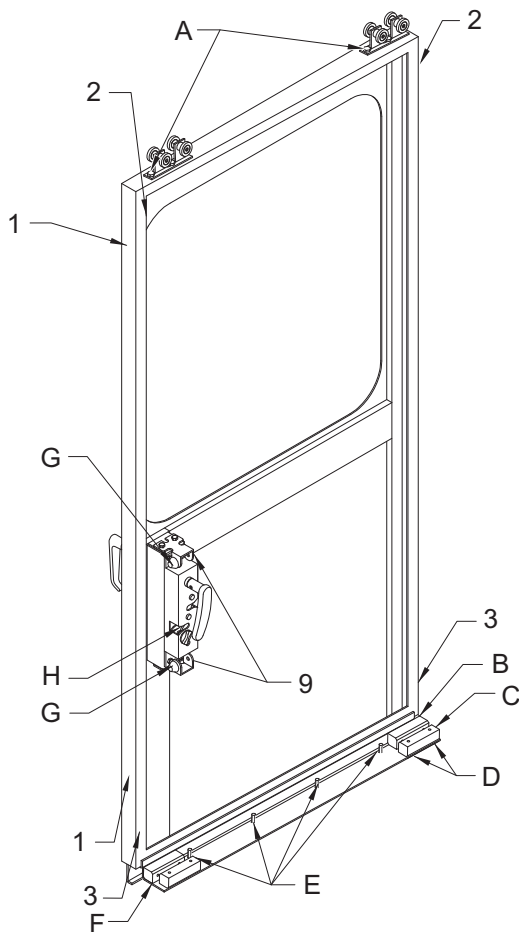

9.10.4 Cab Tilting

Description

The cab can be tilted to 45° by means of the hydraulic system. The cab can be tilted to 90°, if needed, by providing a suitable hoist to carry the weight and disconnecting the lift cylinder.

A hydraulic cylinder mounted between the deck and the frame at a front corner raises and lowers the cab. The hydraulic pump is actuated by a well-marked switch on the outside of the rail near the rear axle. Also provided is a lanyard by which to unlock the cab safety prop during the raising or lowering operation.

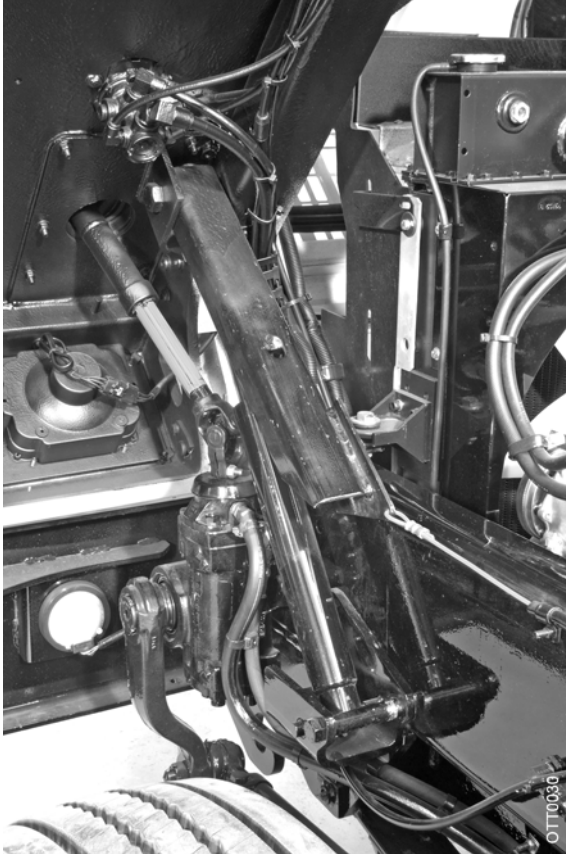

Cab Tilt Cylinder and Safety Prop



Left Front Cab Tilt Pivot

The cab attaches and pivots in front on two pins. The pins are fastened to the front ends of the rails.

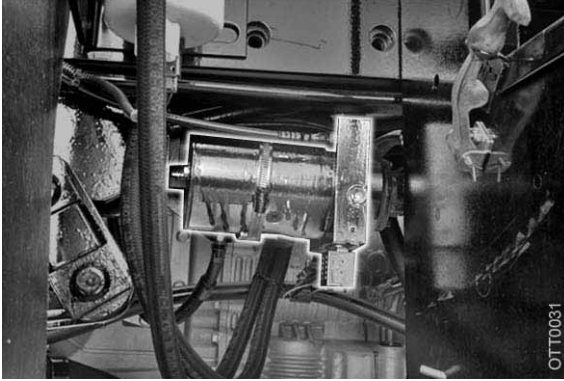

Electric Pump Motor — Cab Tilt System

The Cab tilt system electric pump motor is mounted under the driver's side frame rail. It serves only the cab's tilting system on the tractor.

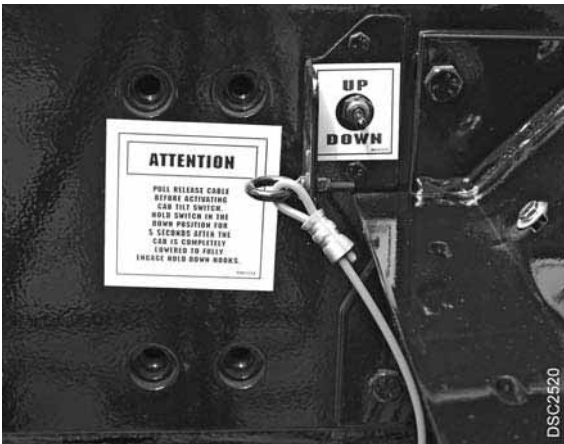

Cab Tilt Control Switch and Lanyard

The cab tilt control switch and lanyard are located on the rail between the hydraulic fluid tank and the rear wheel. Tilt action stops when the switch is released or when the cab reaches full up or full down position.

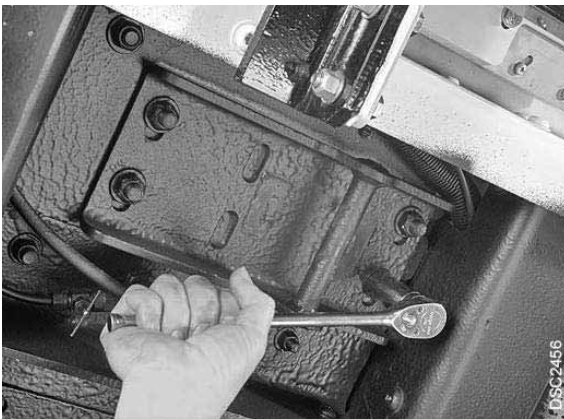

Cab Suspension Latching Bar

After the cab reaches the full down position, the latching mechanism makes a loud sound. The latching bar alignment can be adjusted. Refer to the repair procedures section for more information.

Cab Tilt (hydraulic) Components



Cab Tilt Cylinder and Safety Prop

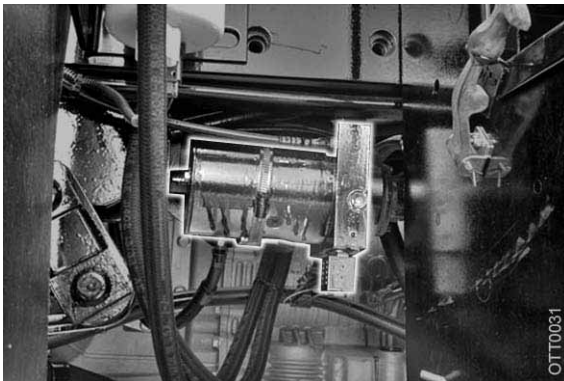

Electric Pump Motor — Cab Tilt

The cab tilt system is an electro/hydraulic system that utilizes the tractor battery to power an electric motor that drives the hydraulic pump. The inlet port of the pump draws in hydraulic oil from the common reservoir. This fixed displacement pump forces the oil through its outlet port, through the valve pressure passage, out the work port, and to the base end of the tilt cylinder. Because of the load, pressure rises until the piston moves the rod, thereby raising the cab. If the switch is held in the **Up** position after the cylinder has fully extended, pressure will rise to the relief setting of 3200 PSI (221 bar). The relief valve will open and pressure will not increase above the set point.

When tilting the cab back down, the solenoid-operated directional control valve (with two positions) is energized. The valve shifts position and allows a return path for oil from the tilt cylinder. A one-way check valve blocks oil returning from the relief valve and pump inlet and directs it through a return filter and through the valve passage. It goes through a restriction, which is pressure compensated, and then back to the pump inlet and on to the reservoir.

When the solenoid-operated control valve is de-energized, a simple spring load returns it to the blocked position. The function of the return restriction is to slow the rate of oil exhausting from the tilt cylinder. The effect of this restriction is to provide a slow, controlled return to the **Down** position for the cab.

Cab Latch — One hydraulic cylinder and one mechanical locking mechanism are utilized to safely secure the cab in the **Down** position. The locking fingers are spring-loaded to the **Lock** position and are unlatched by the cylinder during the tilt up operation. The latching cylinder simply tees into the work line that connects to the base end of the tilt cylinder.

The latch cylinder and the tilt cylinder receive hydraulic oil under pressure at the same time. Since the latch cylinders require less pressure to operate, they will unlatch prior to the lifting of the cab. After they are unlatched and pressure rises, the tilt cylinder will extend, raising the cab.

Cab Tilt Safety Prop — An additional mechanical safety device is used to ensure that the cab cannot be inadvertently lowered. The cab safety prop is similar to a hood prop in function; but instead of holding the hood (or cab in this case), it acts as a solid arm locking the hydraulic tilt cylinder in the extended (cab-tilted) position. It is cable-operated from the tilt operation station where the control switch is located.

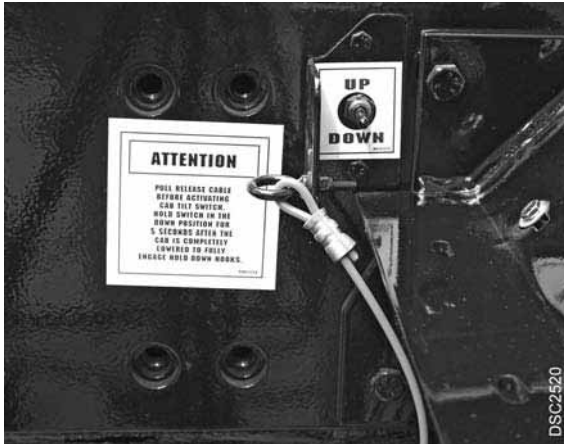

Cab Tilt Control Switch and Lanyard

Diagnosis (Cab Tilt)

Components

- Stop/Tilt Circuit Breaker 20A
- Tilt Pump Control Switch
- Tilt Pump Motor
- Tilt Solenoid

DANGER

Do NOT work under the raised cab before ensuring that the cab safety prop is locked in position. Failure to heed this danger could result in severe personal injury or death.

Cab Tilt Diagnosis

Observation	Cause	Action
Inoperative pump	Electrical	See Electrical section.
Motor runs — cab does not tilt	Low fluid Line leakage	Add fluid as needed. Locate and repair.

9.10.6 Roof and door mouldings

Description

The roof of the standard cab rises at an angle from the windshield permitting a rear door opening approximately 68 inches (1.73 m) high.

9.10.7 Cab Tilt Cylinder

Repair (Cylinder Removal)

WARNING

1. The hydraulic fluid in the system is under pressure. Care should be taken whenever the system is opened. Loosen fittings slightly and allow pressure to bleed off before removing hoses.
2. Safety glasses must be worn when working on the hydraulic system.
3. Use a safety strut to hold the cab in the raised position when the cylinder is removed.

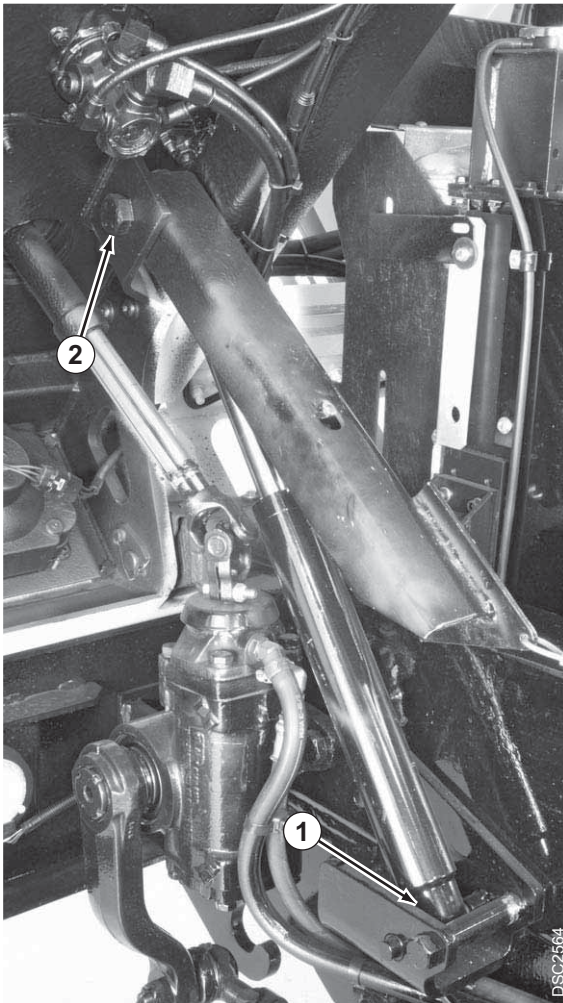

1. Raise the cab using the cab tilt system.

NOTE

If unable to raise the cab using the cab tilt system due to component failure, use the following steps to raise the cab.

- a. *Release the cab latch by supplying hydraulic pressure to the latch mechanism. This can be done by engaging the cab tilt pump or, if the pump is not functioning, by attaching a small hand or electric pump to the hydraulic line for the latch.*
 - b. *Secure an overhead hoist to the rear of the cab and raise the cab to its full-tilt position.*
2. Place a safety bar between the bottom of the deck and the frame in a manner that prohibits the safety bar from slipping.
 3. Using the cab tilt switch (or overhead hoist, if necessary), lower the cab until it rests on the safety bar and all pressure is removed from the cylinder.
 4. Clean the area around the hose fitting on the pump with compressed air to reduce the possibility of contamination.
 5. Position a catch can under the fitting to prevent spills.
 6. Remove the hydraulic line from the cylinder.
 7. Plug or cap the hose end to prevent contamination; secure the line above the frame rail to prevent loss of hydraulic fluid.

8. Remove the cab tilt cylinder from the vehicle as follows:

2000 year model and newer trucks — Remove the cotter key (1) from the support pin securing the lower end of the cylinder to the lower cylinder mounting bracket. While supporting the cylinder, remove the locknut and bolt (2) securing the upper end of the cylinder to the deck.

1999 year model and older trucks — Remove the cylinder support bolt from the lower end of the cylinder and remove the cylinder from the vehicle.

Repair (Cylinder Installation)

1. Prior to reassembly, inspect all fasteners, including support pins, bolts, nuts, etc., for damage and/or wear. Replace all parts that are damaged or show wear.
2. Support the cab tilt cylinder in place on the vehicle while installing the locknuts and bolts to attach the rear end of the cylinder to the mounting bracket on the frame rail. Tighten the locknuts and bolts to 200 ft. lbs (271 Nm).
3. Attach the front end of the cylinder to the mounting bracket on the frame as follows:

2000 year model and newer trucks — Install an adjustable collar around the cylinder and through the mounting bracket and cylinder eye.

1999 year model and older trucks — Install the bolt and locknut through the bracket and cylinder mounting eye and tighten to 200 ft. lbs (271 Nm).
4. Unplug the hydraulic hose end and connect it to the cylinder port.
5. Connect the electrical cables to the relay on the bottom of the cylinder.
6. Using the cab tilt switch, raise the cab and remove the safety bar.
7. Again, using the cab tilt switch, raise and lower the cab to bleed all air from the system; the system is self-bleeding.
8. Check all hoses and fittings for leaks.
9. Check the fluid level in the hydraulic tank; adjust as necessary.

9.10.10 Cab Mounting and Suspension

Description

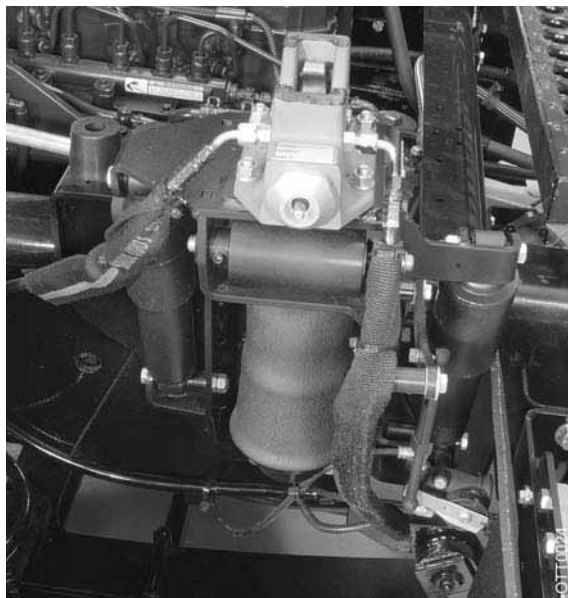

Cab Air Suspension and Latching System

Three-point suspension means that the cab is attached at two points in front by a pivot on each rail and latches to an air suspension system on one rail at a rear corner. The system consists of a latching catch bracket, two shock absorbers, an air cushion and an adjustable height control valve. Air is supplied via the vehicle air system. Correctly adjusted, the system controls the ride height and relieves stress on the cab pivots.

A cab leveling valve works automatically when a load is applied (e.g., when someone steps into the cab or pulls down strongly on a cab entry handle). The flow of system air for adjustment is audible. The sound can be used to determine the serviceability of the valve. Adjustment should be complete in two to 10 seconds.

Diagnosis (Cab Air Suspension)

Components

- Cab Leveling Valve
- Cab Shock Absorbers

Cab Leveling Valve and Shock Absorber Diagnosis

Observation	Cause	Action
Cab leveling too fast or too slow	Clogged leveling valve	Inspect. Replace as needed.
Uncontrolled cab bounce	No air in airbag	Turn on air ride air valve.
	Shock absorbers worn	Inspect. Replace as needed.
	Worn out cab pivot bushings	Replace cab pivot bushings.

9.10.11 Air Ride Suspension (Three-Point)

Repair (Cab Suspension Assembly Removal)

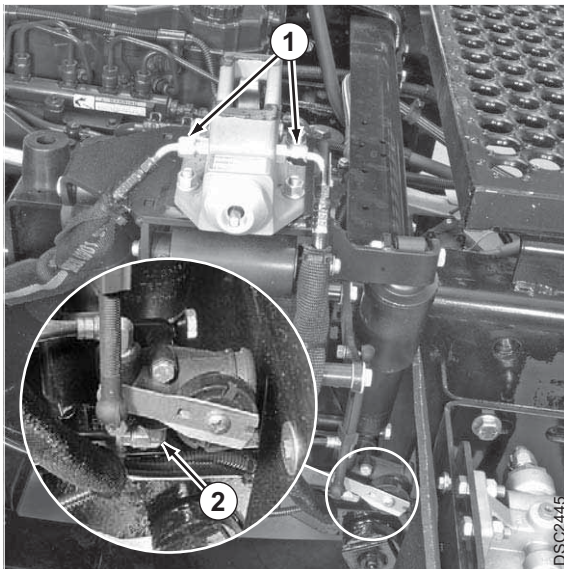
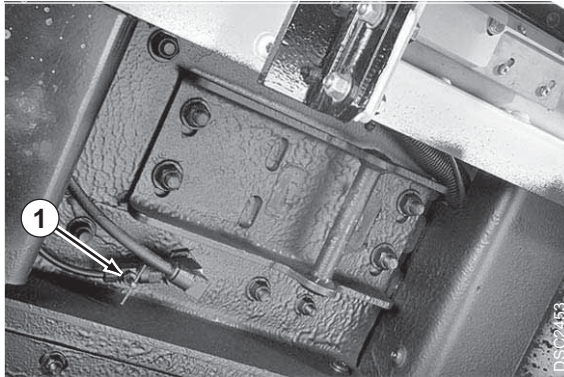

1. Park the vehicle on firm level ground.
2. Raise and support the cab.
3. After the cab is raised and supported, briefly press the cab “tilt” switch to the “DOWN” position. This will evacuate extra fluid from the cylinder.
4. Turn off the air supply to the cab suspension by turning the small “T-handle” valve (1) clockwise. It is located next to the latch bar plate on the bottom of the deck.
5. Disconnect and cap the hydraulic lines (1) connected to the latch at the top of the suspension assembly.
6. Disconnect the air line (2) from the leveling valve on the suspension assembly.
7. Remove the four mounting bolts (3, 4) securing the suspension assembly to the frame rail (driver's side).

Repair (Cab Suspension Assembly Installation)

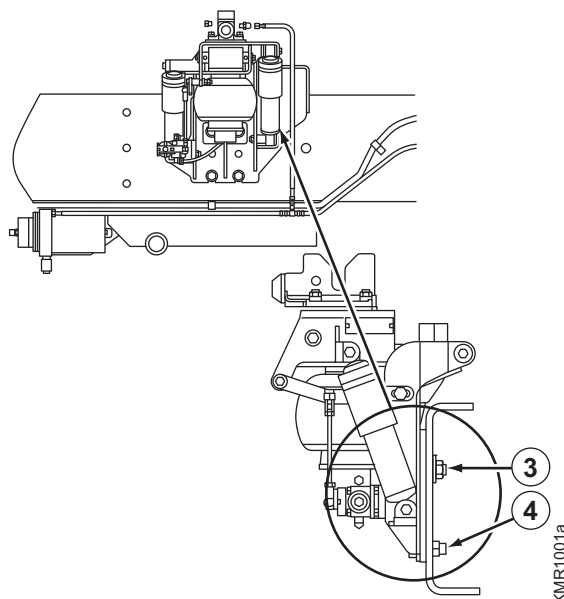

1. From the inner side of the frame rail, insert bolts into the two lower suspension mounting holes. These bolts will support the suspension assembly as it is placed in position in the next step.
2. Align the air suspension assembly with the two lower mounting bolts (4) and place it in position against the frame rail.
3. Install the bolts, washers and locknuts (3) in the two upper mounting holes to secure the suspension assembly to the frame.
4. Install the washers and locknuts on the lower mounting bolts (5). Tighten all four mounting bolts and nuts (3, 4) to 220 ft. lbs (298 Nm).
5. Reconnect the hydraulic lines to the latch at the top of the assembly.

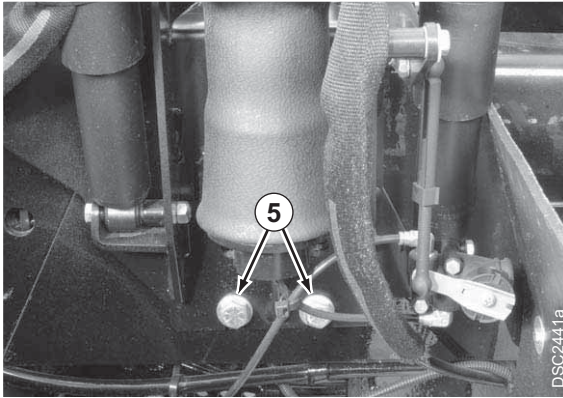

6. Reconnect the air line to the suspension leveling valve.
7. Secure all hydraulic lines away from moving parts.
8. Loosen the cab latch bar plate on the bottom of the cab deck.
9. Lower the cab slowly until the cab latch bar plate makes contact with the air suspension latch. Adjust the latch bar plate until it is centered in the latch and hand tighten the outer mounting nuts.
10. Raise and support the cab. Then, tighten all four of the latch bar plate mounting nuts to 65 ft. lbs (88 Nm).
11. Make sure all lines are routed away from the rubber bumper contact area on the deck. Reroute and secure the lines if necessary.
12. Check the hydraulic lines for leaks.

NOTE

After 100 hours of operation — Recheck fasteners for tightness.

Repair (Air Ride Level Adjustment)

1. Park the vehicle on firm level ground.
2. Start and run the engine until the air system has a minimum of 100 psi of air pressure.
3. Shut the engine down.
4. Turn on (open) the air supply to the cab suspension by turning the “T-handle” valve on the bottom of the deck counter-clockwise.
5. Remove the plastic clip (2) in the center of the plastic linkage rod connected to the control arm on the suspension assembly.
6. Use tape to mark the linkage rod's current position (3).
7. Adjust the linkage rod length as required to set proper ride height. Disengage the serrated lower end (4) of the rod from the serrated portion of its upper sleeve (1):

To raise ride level — *Decrease* the rod (4) length by placing the rod deeper into the upper sleeve (1).

To lower ride level — *Increase* the rod length by reducing the insertion of the rod in the sleeve.

NOTE

One inch (25.4 mm) of clearance is required between the stop bumpers on the air suspension assembly and the channel at the bottom of the cab deck for proper ride height.

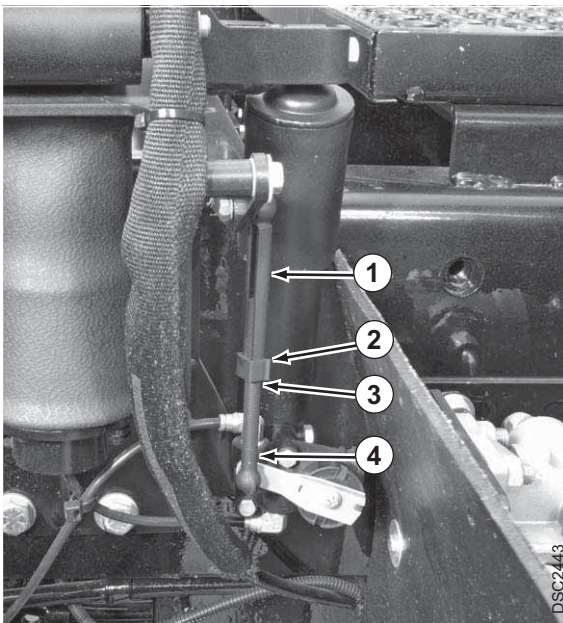

9.10.12 Leveling Valve

Repair (Valve Operation Check)

Check for proper operation of the leveling valve as follows:

1. While holding the cab entry handle in the “DOWN” position, count the time in seconds it takes for the air spring to raise the ride height.
2. If the noted time is:
 - Within 2–10 seconds** — Valve is OK.
 - Under 2 seconds** — Valve is damaged or filter is clogged.
 - Over 10 seconds** — Valve is damaged or filter is clogged.
3. Replace the valve if the valve is damaged or the filter is clogged.

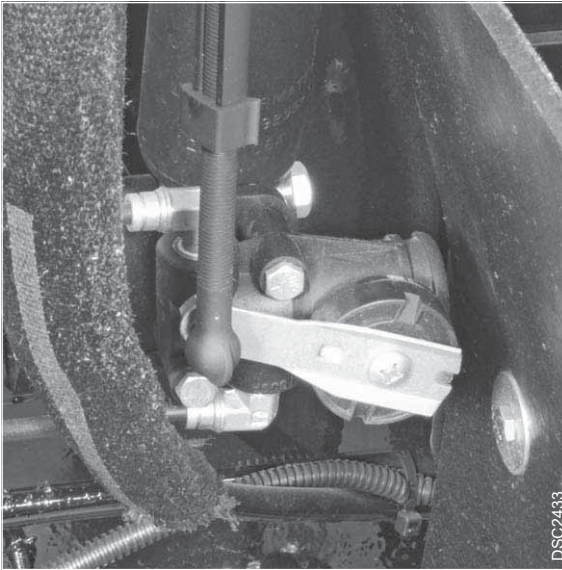

9.10.13 Shock Absorbers

Repair (Shock Removal)

Replacement of the shock absorber is necessary if the cab ride becomes too bouncy under normal operating conditions.

1. Raise the cab and lock it in the full-tilt position.
2. Remove the nuts (1) from the 7/16-inch mounting bolts securing the shock absorber in the top and bottom mounting brackets at one side of the suspension assembly.
3. Remove the bolts and remove the shock absorber from the assembly.
4. Repeat the procedure to remove the second shock absorber at the opposite side of the assembly.

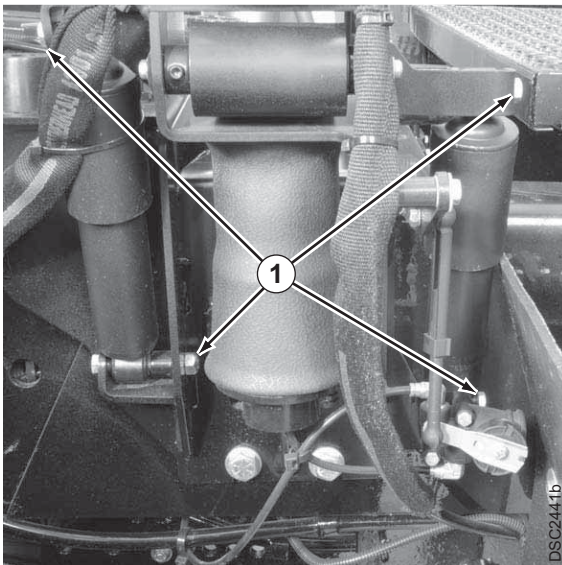

Repair (Shock Installation)

1. Place the shock absorber in position between the mounting brackets at the side of the suspension assembly.
2. Install the 7/16-inch bolts and nuts to secure the shock absorber in the top and bottom mounting brackets.
3. Tighten the bolts and nuts to specification.
4. Repeat the procedure to install the second shock absorber at the opposite side of the assembly.
5. Unlock the cab tilt cylinder and lower the cab.

9.10.4 Cab Latch Bar Plate

Repair (Latch Bar Plate Adjustment)

The position of the cab latch bar plate is important. When properly positioned, it relieves stress on the cab/deck assembly. To properly position the cab latch bar plate, use this procedure.

1. Raise the cab and loosen all four nuts (1, 2) securing the cab latch bar plate to the bottom of the cab deck.

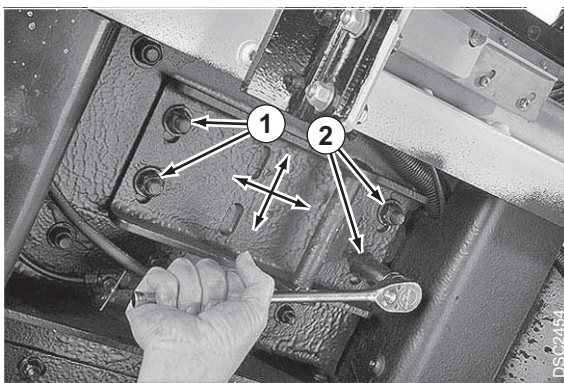

2. With the plate loosened, lower the cab slowly ensuring the latch bar properly seats in the hold down latch (3) at the top of the suspension assembly.
3. Make adjustments (side-to-side, fore and aft) to center the bar in the latch.
4. Tighten the two nuts (1) which are accessible at the outer end (long end) of the cab latch bar plate.
5. Raise the cab and tighten all four (1, 2) cab latch bar plate mounting nuts to specification.
6. Lower the cab and recheck the position of the bar in the latch. Readjust if necessary.

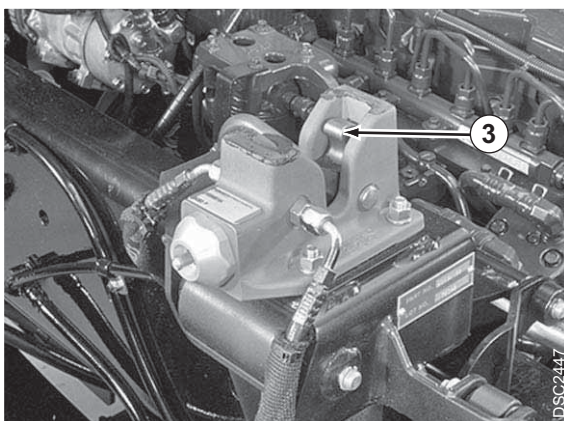

9.10.6 Cab Tilt Pump and Motor

Diagnosis (cab tilt pump)

Components

- Stop/Tilt Circuit Breaker 20A
- Tilt Pump Control Switch
- Tilt Pump Motor
- Tilt Pump Solenoid

Cab Tilt Pump Circuit Diagnosis

Observation	Cause	Action
Inoperative motor	Circuit breaker open	Reset. Repair short as needed. Replace circuit breaker as needed.
	Defective tilt pump control switch	Replace.
	Defective tilt pump solenoid	Replace.
	Defective wiring	Inspect connections and wires. Test circuits. Repair or replace as needed.
Raised cab does not return	Circuit breaker open	Reset. Repair short as needed. Replace circuit breaker as needed.
	Defective tilt pump control switch	Replace.
	Defective tilt pump valve	Replace.
Motor operates — cab does not rise		Refer to Hydraulic section.

Repair (Pump and Motor Removal)



WARNING

The hydraulic fluid in the system is under pressure. Care should be taken whenever the system is opened. Loosen fittings slightly and allow pressure to bleed off before removing hoses.

Safety glasses must be worn when working on the hydraulic system.

The cab tilt pump and motor are located on a bracket below the left main frame rail just rear of the engine with the cab tilt cylinder.

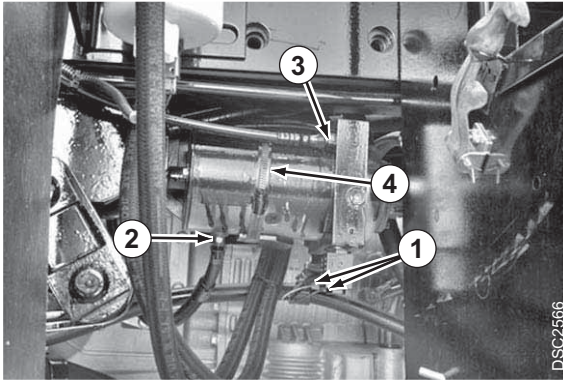

1. Disconnect the negative cable from the battery.
2. Locate and disconnect the two wires (1) at the solenoid under the pump motor.
3. Locate and disconnect the battery cable (2) at the pump motor.
4. Clean the area around the hydraulic hose fittings on the pump with compressed air to reduce the possibility of contamination.
5. Position a catch can under the valve to prevent spills.
6. Disconnect and cap the two hydraulic lines (3) attached to the pump.
7. Remove the two mounting bolts, flatwashers and locknuts; remove the adjustable collar (4) from around the center of the pump and then remove the pump and motor assembly.

Repair (Pump and Motor Installation)

1. Place the cab tilt pump and motor assembly in position on the frame rail mounting bracket. Install the two mounting bolts, flatwashers and locknuts; tighten securely. Install the adjustable collar around the center of the pump.
2. Uncap the hose ends and connect the two hydraulic lines to the pump.
3. Connect the two wires to the solenoid under the pump motor.
4. Connect the battery cable to the pump motor.
5. Check the fluid level in the hydraulic tank.
6. Connect the negative cables from the batteries.
7. Using the cab tilt switch, raise and lower the cab to bleed all air from the system; the system is self-bleeding.
8. Check all hoses and fittings for leaks.
9. Check the fluid level in the hydraulic tank; adjust as necessary.

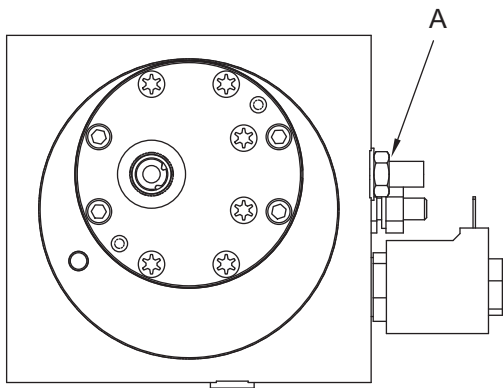

Repair (Relief Pressure Adjustment (2001 and Newer Trucks))

1. Raise the cab to the full-tilt position. Check to ensure that the safety latch has engaged.
2. Slightly loosen the fitting at the cab tilt cylinder to relieve system pressure.
3. Install a “T” fitting in the supply line from the pump to the cab latch and connect a hydraulic pressure gauge to the fitting.
4. Locate the adjusting screw (A) on the pressure relief valve body. The valve can be found between the inlet port on the pump and the motor.
5. While holding the adjusting screw with an Allen wrench, loosen the jam nut.
6. With the cab raised all the way up, hold the tilt control switch in the “UP” position. Note the reading on the hydraulic pressure gauge.
7. Turn the adjusting screw in or out as required to reach the specified relief pressure. For settings see *Hydraulic System* in the *Technical Data* section.
8. Using an Allen wrench, hold the adjusting screw in place and tighten the jam nut securely.
9. Disconnect the hydraulic gauge and remove the “T” fitting from the supply line; reconnect the supply line.
10. Check the supply line hose and fittings for leaks.
11. Lower the cab.

9.10.7 Cab Pivot Bushing

Repair (Pivot Bushing Removal)



WARNING

Make sure all safety devices are in place while the cab is in the raised position.

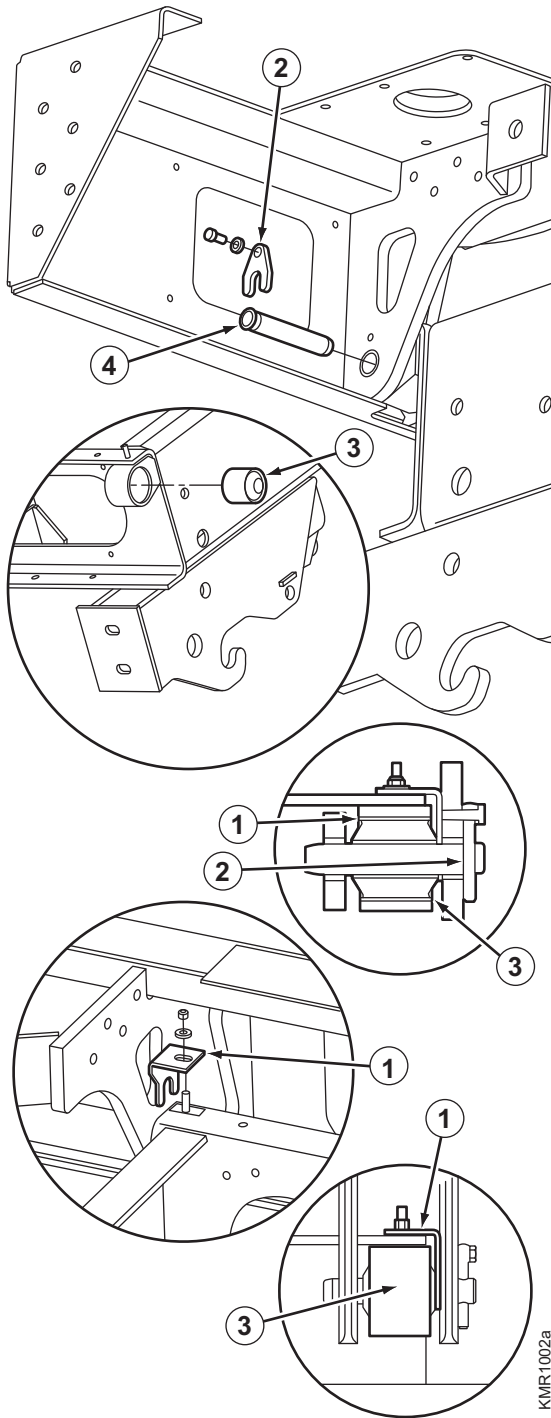

1. Raise the cab to the full-tilt position and make sure the safety arm is in place.
2. Remove the SNAPTRAC® bolts from the left front corner of the frame cross member and from the bottom of the cab channel. Allow the SNAPTRAC® to hang loose.
3. Remove the p-clamp that secures the frame and engine harnesses at the left front corner of the front cross member.
4. Remove the heater hose p-clamp at the front right top of the frame cross member.
5. Remove the spacer bracket (1) at the front left cab pivot pin.
6. Remove the cab pivot retainers (2) from the pivot pins at the left and right sides of the cab.
7. Remove both front headlight buckets.
8. Place 4x4x6-inch blocks on the top of the frame rails to support the cab, then lower the cab onto the blocks. This will help stabilize the cab while removing the cab bushings (4).

NOTE

The blocks should be of sufficient thickness to fill the space between the frame rails, cab deck channels and pivot brackets. This will support the cab in the ride level position when the pivot pins are removed.

9. Stabilize the right rear of the cab deck by chaining it down.
10. Using a drift, drive the front cab pivot pins (4) out.
11. Using the cab tilt switch, operate the switch in the “UP” position until the cab deck has cleared the cab tilt bushings in the frame.
12. Support the front of the cab deck by placing additional blocks between the deck and frame.
13. Using a drift, drive the old bushings out of the left and right cab pivot blocks.

Repair (Pivot Bushing Installation)

1. Install new bushings into the cab pivot blocks.

NOTE

The bushings are a light press-fit.

2. Remove the additional blocks placed in position to support the cab in the raised position after the pivot pins were removed.
3. Using the cab tilt switch, lower the cab deck down to the desired height on the original blocks placed in position to support the cab. Install the cab tilt pins.
4. Install the cab pivot retainer (2) at each pivot pin.
5. Install the spacer bracket (1) at the front left cab pivot pin.
6. Install both front headlight buckets.
7. Install the p-clamp that secures the frame and engine harnesses at the left front corner of the front cross member.
8. Install the SNAPTRAC® bolts at the front left corner of the frame cross member and from the bottom of the cab channel.
9. Lower the cab and check for hose routing issues.

9.12 Chassis

Description

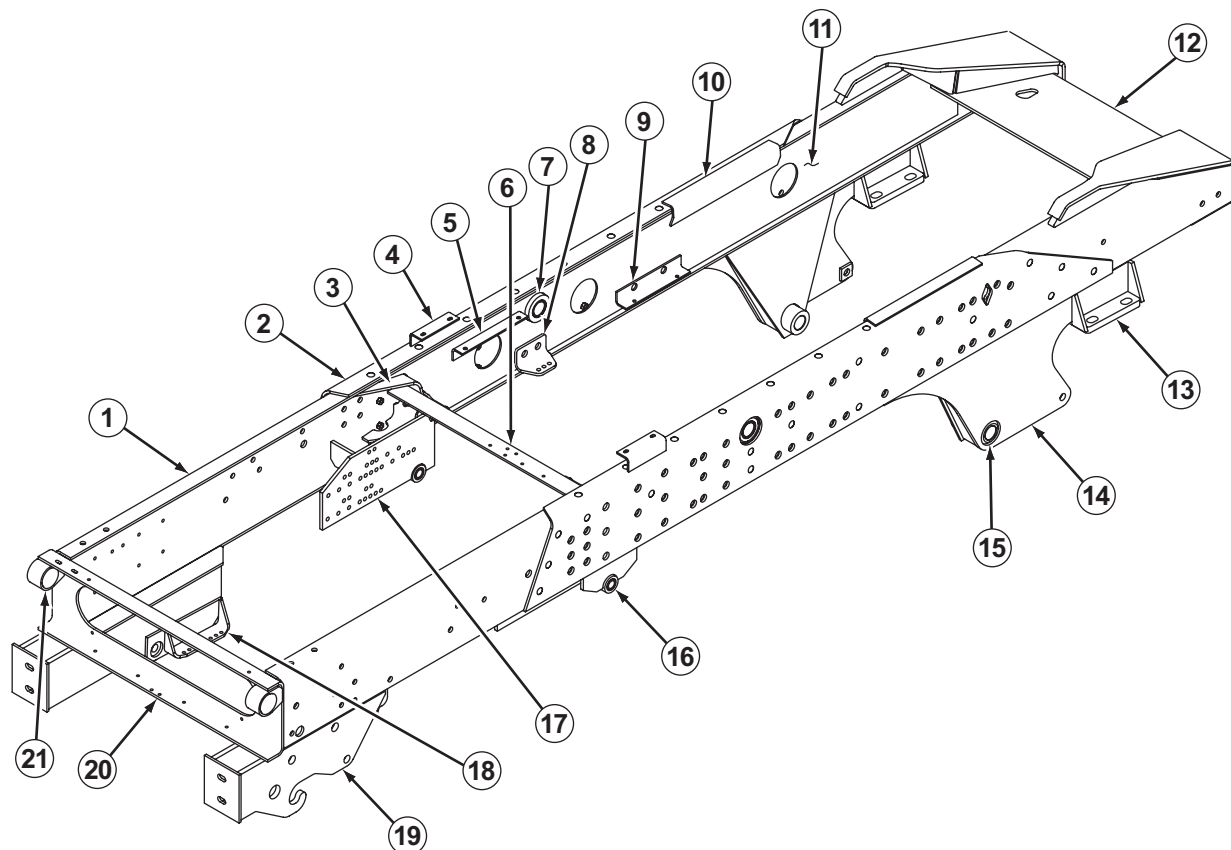

Frame Construction

OTT0070

1. Main Rail (2)	12. Weldment, Cross Member and Ramps
2. Inverted-L Channel Rail Reinforcement (2)	13. Axle Mounting Bracket (2)
3. Triangular Brace (2)	14. Boom Lift Cylinder Mounting Weldment (2)
4. Inverted-L Channel Welded Riser (2)	15. Boom Lift Cylinder Pivot Bushing
5. Inverted-L Channel Welded Support (2)	16. Front Spring Rear Mounting Bracket (2)
6. Inverted-L Channel Median Cross Member	17. Rear Motor Mount (2)
7. Fifth-Wheel Boom Pivot Bushing (2)	18. Front Motor Mount (2)
8. L Channel Support (2)	19. Front Spring Front Mounting Bracket with Tow Hook (2)
9. L Channel Support (2)	20. Front Cross Member
10. Inverted-L Channel Welded Reinforcement (2)	21. Cab Pivot Pin Bushing (2)
11. Rail Reinforcing Plate (2)	

The frame rails are reinforced C channels. Flat plates are welded to the upper and lower flanges of each rail near the outer edges forming boxes. These plates reach from the cross member at the rear end of the cab to a point under the ramp at the rear ends of the rails. The cross member is bolted to triangular braces welded to the forward ends of these plates. The triangular braces are also welded to the upper flanges of the rails.

Inverted L-shaped reinforcements are welded to the outside of the C channel stretching from the cross member to the rear axle. Other short inverted L-shaped pieces are welded to the tops of the flanges near the fifth wheel. Short, upright L-shaped reinforcements support the lower flanges of the rails at strategic points.

There is one cross member located near the rear of the cab. In front, the rails are held square by the weldment that anchors the cab pivot pins and in the rear by the weldments that form the ramp.

A weldment structure extends downward from each rail ahead of the rear axle to provide anchor points for the lower ends of the boom cylinders. The front end of the boom rides in pivot points through the rails.

Additional reinforcements are welded to the rails in locations designed to provide extra support for the frame under high torsional or shock loads.

Diagnosis (Chassis)

Components

- Frame

NOTE

Frame rails are not serviceable. For repair or replacement, contact Kalmar service department.

Frame rails that are out of shape must be straightened and properly aligned to restore the vehicle to maximum capacity and safe performance.

If the cause of misshapen rails is overloading, continuing safely in such heavy service requires that the rails be reinforced after reshaping and alignment.

If the failure is the result of too many or improperly located holes in one or both rails, the frame should be replaced unless safe practice will permit adding reinforcement.

Always follow the guidelines for adding reinforcement to the rails and for drilling holes in the rails.



WARNING

Welding produces so much heat that there is a risk of changing the physical properties of the steel in the frame rails. If the vehicle may be economically re-stored to service by means of welding, contact Kalmar service department, or ensure that best welding practices are rigorously followed so as to avoid changing the properties of the steel. Failure to heed this warning may result in severe property damage.



WARNING

Do NOT cut the rails or holes in the rails using a welding torch. Do NOT drill holes in top or bottom rail flanges. Failure to heed this warning may result in severe property damage.

Frame Diagnosis

Observation	Cause	Action
Cracked rails	Loose bolts	Install larger bolts. Refer to instructions for repairing cracked rails elsewhere in this manual. Reinforce rail.
	Overloading	Refer to instructions for repairing cracked rails elsewhere in this manual. Reinforce rail.
Sagging rails	Overloading	Straighten, reinforce and align the rails, or replace the frame as needed.
	Uneven loading	
	Holes in rail flange	
	Too many rail web holes	
	Rail web holes too close together	
	Four or more rail web holes aligned vertically	
	Welds on flange	
No filler blocks		

Observation	Cause	Action
	Rail web holes cut with torch Notches anywhere in rails Vehicle fire Vehicle collision Equipment added beyond vehicle capacity	
Buckled rails	Fifth wheel raised to maximum while maneuvering a loaded trailer Equipment added beyond vehicle capacity Load shift (e.g., surging liquid) in a loaded trailer Vehicle fire Vehicle collision Rails weakened by added holes, notches, extraordinary welding or cutting	Straighten, reinforce and align the rails, or replace the frame as needed.
Misaligned rails	Misaligned axle or weak spring. These conditions may give the appearance of misaligned rails. Vehicle collision Towing load attached to one rail Operating over rough terrain	Inspect. Repair as needed. Straighten, reinforce and align the rails, or replace the frame as needed.
Improper tracking	Improper front end alignment Misaligned rails Misaligned axle	Align the front end. Straighten, reinforce and align the rails, or replace the frame as needed. Align the axle.

Repair (Frame Damage Analysis)

This section is not intended to cover the causes of all possible frame problems; however, it should be of valuable assistance in preparing complete, concise reports. The purpose of this information is to emphasize the fact that frame damage doesn't just happen, there is always a cause or reason. An example of this would be a vehicle involved in a collision. The reason for damage in this case is apparent; however, other damages can be encountered where the reasons are not so apparent.

Three types of frame damage can be classified as follows:

1. Collision
2. Excessive bending moment
3. Localized stress concentration

Damage caused by collision should be repaired using proper methods and reinforcement. Excessive bending moment damage is caused by overloading, improper weight distribution, or misapplication of the vehicle. Excessive bending moment damage will occur at different areas on various types of vehicles. The effects of excessive bending moment will vary by type of vehicle.

Repair (Making Reinforcements, General Information)



CAUTION

When welding on a Kalmar truck:

1. **Always disconnect the wiring at the battery terminals and ECUs.**
2. **The ground for the welder should always be attached as close as possible to the work area.**
3. **Failure to adhere to these cautions can result in permanent damage to the electrical system.**

In general, when making reinforcements of any type, observe the following practices.

1. Contact the Kalmar Engineering Department for design approval.
2. Taper reinforcement plates to avoid abrupt changes in section modulus. Angles at the edge of a reinforcement plate should be less than 45 degrees.
3. When reinforcement plates are shaped by use of a cutting torch, all cracks, nicks, and burrs must be removed from the edges by grinding. Burrs must also be removed from the edges of holes.

4. Make reinforcements long enough so that they can be tapered and still extend beyond the critical area.

Repair (Making Reinforcements, Attachment)

Reinforcements must be attached with grade 8 bolts, locknuts and hardened washers on both ends of the bolt. This provides a good torque surface to maintain tight bolts. Avoid attaching reinforcements by welding. (In some cases, welding may be acceptable. Such cases include the plug weld used on strap or web reinforcements.) Bolt holes that are enlarged or irregularly worn may be reamed to accept the next larger bolt diameter. For critical areas, body-fit bolts require reaming the hole to a nonstandard size to effect an interference fit for the bolt. Whenever possible, use existing frame holes rather than drill new ones.

In general, when attaching reinforcements to the frame, use bolts and observe the following:

1. Use existing holes, if possible.
2. Do not drill holes in the frame flange.
3. Holes should be made as close to the neutral axis (halfway between the flanges) as possible.
4. Bolt holes should be no larger than those already existing in the frame.
5. No more than three holes should be on a vertical line of the web.
6. Holes should be at least 3/4 inch (19.0 mm) apart.
7. Holes in a reinforcement plate should be at least two times the material thickness from the edge of the plate.

Repair (Cracks in Steel Rails or Cross Members)

Type of Cracks

The straight crack and the sunburst crack are the two common types. The straight crack will normally start from the edge of a flange. It will progress across the flange and through the web section of a rail. Ultimately, it will continue through the other flange. This type of crack may result from high concentrations of stress in small areas of the frame, excessive bending moment, and torsion loading. Sunburst cracks will radiate out from a hole in the web section of a rail or cross member. They are caused by high loads being applied at a mounting bracket or cross member, which is not securely or properly attached to the rail. If cracks occur to both the rail and reinforcement of a steel frame, they must be repaired separately. The flanges must react independently to prevent localized stress concentrations. Use a copper spacer between the flanges of cracked base rail flanges and reinforcement flanges. Cross member mounting flange cracks may be repaired in the same manner as side rail cracks. However, the weld bead should be built up to provide a

good smooth radius. If extensive damage is incurred to a cross member, the cross member should be replaced. It may be necessary to align the frame and level the rails before repairing the frame.

The following procedure should be used to repair cracks in a rail, reinforcement or cross member.

1. Remove any equipment that will interfere with access to the crack.
2. Locate the extreme end of the crack and drill a 1/2-inch (12.7 mm) hole.
3. V-grind the entire length of the crack from the starting point to the hole at the extreme end. The angle of the "V" will depend on the welding process used.
4. The bottom of the crack should be opened up 1/16 inch (1.6 mm) to allow good penetration of the weld. (A hacksaw blade may be used for this.)
5. Weld with the proper electrode and proper welding techniques.
6. Grind the weld smooth on both the inside and outside of the rail or cross member. Be extremely careful to eliminate weld buildup or notches on the edge of the flange.

9.13 Bodywork

9.13.3 Footstep

Description

A two-step ladder is attached to the cab deck by the side door. In addition, three steps made from 10-gauge perforated steel are mounted on the battery box for access to the frame decking and the rear door. Grab handles designed to accommodate entry to either door are attached to the rear cab wall.

Perforated decking made from 10-gauge steel is attached across the frame rails at the rear of the cab. Additional perforated decking extends toward the fifth wheel on top of the boom.

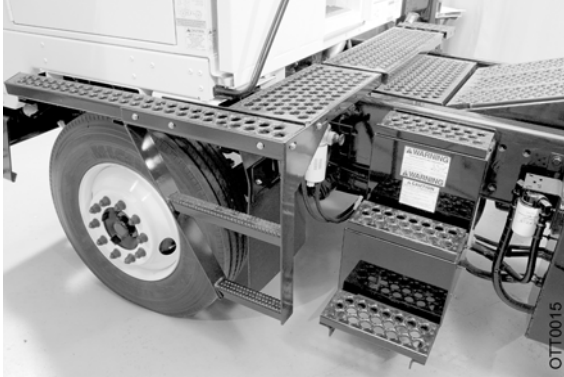

Cab Access Ladders and Decking

9.16 Accessories and options

9.16.1 Accessory Relay

Diagnosis

Components

- Accessory Circuit Breakers
- Accessory Relay
- Ignition Switch

Accessory Relay Circuit Diagnosis

Observation	Cause	Action
One accessory inoperative	Circuit breaker open	Reset. Repair short as needed. Replace circuit breaker as needed.
All accessories inoperative	Defective relay Defective wiring	Replace. Inspect connections and wires. Test circuits. Repair or replace as needed.

9.16.2 Heater/Air Conditioning (Optional)

Diagnosis

Components

- AC On/Off Switch
- Blower Motor
- Cold Control
- Heater/AC Relay
- Heater Resistor Block
- Heater Switch
- Ignition Switch

Heater/Air Conditioning Circuit Diagnosis

Observation	Cause	Action
Inoperative blower	Circuit breaker open	Reset. Repair short as needed. Replace circuit breaker as needed.
	Defective resistor	Replace.
	Defective heater switch	Replace.
	Defective heater/AC relay	Replace.
	Defective wiring	Inspect connections and wires. Test circuits. Repair or replace as needed.

Observation	Cause	Action
	Defective blower motor	Replace.
Blower operates at one or two speeds only	Defective resistor	Replace.
	Defective heater switch	Replace.

9.16.3 Mirrors (Heated/Motorized)

Diagnosis

Heated and Motorized (remotely controlled) mirrors are optional equipment.

Components

- Mirrors
- Mirror Heat Switch
- Motorized Mirror Switch (Left-Hand)
- Motorized Mirror Switch (Right-Hand)

Heated Mirror Circuit Diagnosis

Observation	Cause	Action
Inoperative heater	Circuit breaker open	Reset. Repair short as needed. Replace circuit breaker as needed.
	Defective heater switch	Replace.
	Defective mirror	Replace.
	Defective wiring	Inspect connections and wires. Test circuits. Repair or replace as needed.

Heated Motorized Mirror Circuit Diagnosis

Observation	Cause	Action
Inoperative heater	Circuit breaker open	Reset. Repair short as needed. Replace circuit breaker as needed.
	Defective heater switch	Replace.
	Defective mirror	Replace.
	Defective wiring	Inspect connections and wires. Test circuits. Repair or replace as needed.
Inoperative motor	Circuit breaker open	Reset. Repair short as needed. Replace circuit breaker as needed.
	Defective motor	Replace.

Observation	Cause	Action
	Defective wiring	Inspect connections and wires. Test circuits. Repair or replace as needed.

10 Common Hydraulics

System Description



WARNING

The hydraulic fluid in the system is under pressure. Care should be taken whenever the system is opened. Loosen fittings slightly and allow pressure to bleed off before removing hoses. Safety glasses must be worn when working on the hydraulic system.

Failure to heed this warning may result in serious personal injury or property damage.

The hydraulic system of the current production Ottawa tractors is composed of three subsystems. They are the boom (hoist), cab tilt and power steering. The common link among these three subsystems is the shared reservoir, return filter and hydraulic fluid. With the exception of these items, all subsystems operate independently. The three subsystems have their own control valves and output actuators (cylinders).

The power steering is an open-centered circuit; that is, hydraulic oil flows continuously through the center of the control valve even while the steering wheel is not moving.

Power steering and the boom systems use the same hydraulic pump. The pump is equipped with a priority valve that directs the first four gallons per minute of flow to the steering circuit.

10.3 Tanks and accumulators

10.3.1 Reservoir

Description

The standard hydraulic reservoir has a 16-gallon capacity. It is fitted with a level sight gauge and a breather.

10.6 Temperature control, cleaning and hydraulic oil

10.6.8 Return filter

Description

The return filter is located near the tank in the boom circuit return line, where it is continuously filtering fluid that is used in all three subsystems: boom, cab tilt and power steering.

11 Common Electric

11.1 Controls and instruments

Description (wiring harness)

The wiring harness can accommodate several items of optional equipment. Contact your dealer for information about any equipment installed after the vehicle left the factory.



Trailer Electrical Connector and Brake Hoses

11.2 Safety

11.2.2 Fuses, relays and circuit breakers

Description

Fuses, Relays and Circuit Breakers — The fuse panel is mounted underneath the instrument panel; on the right hand-side for right hand drive vehicles, on the left hand side for left hand drive vehicles. The relay panel is mounted under instrument panel 1. The fuse panel cover includes diagrams of the panels.

12 Common pneumatics

12.1 Air System and Brakes

Description

The main function of the vehicle air system is to provide compressed air to operate the brakes. Compressed air also operates the cab suspension, driver's seat suspension and posture features, fifth-wheel unlatching, trailer brakes and optional interaxle lockout.



DANGER

Only trained air brake technician must be allowed to service the air brakes. Failure to heed this danger could result in severe personal injury or death.

12.1.1 Diagnosis

Brakes — Air System

A DOT/EPA system includes three reservoirs: primary, front and rear. Off-highway vehicles have only two reservoirs: supply and service.

Components

- Air Compressor
- Air Control Valve
- Air Dryer (Optional)
- Antilock Modulator Valve (Optional)
- Automatic Slack Adjusters
- Bobtail Proportioning Relay Valve (Optional)
- Brake Valve (treadle)
- Check Valve
- Double Check Valve
- Front Brake Chambers
- Governor
- Low Pressure Indicator
- Pressure Protection Valve
- Pressure Relief Valve
- Quick Release Valve

- Rear Brake Chambers
- Reservoirs (DOT/EPA: primary, front and rear) (Off-Highway: supply and service)
- Stoplight Switch
- Tractor Protection Valve

Brakes — Air System Diagnosis

Observation	Cause	Action
Frequent air dryer purging (cycling)	Excessive system leakage	Inspect system connections and valves. Repair or replace as needed.
	Defective internal check valve	Test. Replace as needed.
	Defective governor	Test. Adjust or replace as needed.
	Purge valve leaks	Test. Replace as needed.
	Compressor unloader leaks	Slight leakage permitted. Uncover inlet cavity and inspect piston. Repair or replace unloader as needed.

Observation	Cause	Action
Water in reservoirs	<p>Desiccant saturated</p> <p>External charge air did not pass through air dryer</p> <p>Air dryer not purging</p> <p>Purge time too short</p>	<p>Replace desiccant cartridge. Refer to Medium Duty Truck Unit Repair Manual.</p> <p>Ensure charge air enters filter valve at compressor.</p> <p>Inspect purge valve. Refer to Medium Duty Truck Unit Repair Manual.</p> <p>Refer to Frequent Purging (Cycling) above.</p>
Dryer safety valve discharging	<p>Desiccant cartridge plugged or saturated</p> <p>Defective internal check valve</p> <p>Defective hose, tubing or fittings between dryer and main supply reservoir</p>	<p>Replace desiccant cartridge. Refer to Medium Duty Truck Unit Repair Manual.</p> <p>Test. Replace as needed.</p> <p>Inspect hose, tubing and fittings for holes, kinks and other restrictions. Repair or replace as needed.</p>
No pressure buildup (continuous exhaust at dryer purge valve)	<p>Purge valve leaking</p> <p>Defective governor</p> <p>Purge control line connected to reservoir or governor exhaust port</p> <p>Defective electrical circuitry</p> <p>Inlet and outlet air connections reversed</p> <p>Defective check valve between dryer and first reservoir</p> <p>Kinked or blocked discharge line</p> <p>Excessive air system leakage</p>	<p>Inspect. Repair or replace air dryer as needed. Refer to Medium Duty Truck Unit Repair Manual.</p> <p>Test. Adjust or replace as needed.</p> <p>Connect to governor unloader port.</p> <p>Test. Repair or replace as needed.</p> <p>Reconnect lines correctly.</p> <p>Test. Repair or replace as needed.</p> <p>Straighten, clean, repair or replace as needed.</p> <p>Inspect system connections and valves. Repair or replace as needed.</p>
Fails to purge	<p>Broken, kinked, plugged or disconnected purge control line</p> <p>Defective purge valve</p>	<p>Test line — compressor unloaded.</p> <p>Inspect. Repair or replace air dryer as needed. Refer to Medium Duty Truck Unit Repair Manual.</p>

Observation	Cause	Action
Desiccant expelled through purge valve	Air dryer vibration Defective desiccant cartridge Defective compressor piston rings Defective electrical circuitry	Inspect. Repair or replace as needed. Inspect. Repair or replace as needed. Inspect supply air. If oil is present, repair or replace compressor as needed. Refer to Medium Duty Truck Unit Repair Manual. Inspect. Repair or replace as needed.
Low air pressure warning	Half of dual system failed System failed Defective governor Defective compressor Excessive air system leakage	Inspect gauges. Repair or replace failed components as needed. Inspect for leaks. Repair or replace failed components as needed. Test. Adjust or replace as needed. Inspect. Repair or replace as needed. Inspect system connections and valves. Repair or replace as needed.
Pressure drops quickly: engine stopped, brakes applied	Treadle valve leak Brake chamber leak Lines or fittings leak	Inspect. Repair or replace as needed. Inspect. Repair or replace as needed. Inspect. Repair or replace as needed.
Pressure drops: engine stopped, brakes applied	Treadle valve leak Lines or fittings leak Spring chamber leak	Inspect. Repair or replace as needed. Inspect. Repair or replace as needed. Inspect. Repair or replace as needed.

Observation	Cause	Action
Pressure does not reach normal	Reservoir drain cocks open Excessive system leakage Poor governor adjustment Defective air pressure gauge Defective air compressor	Inspect and close as needed. Inspect system connections and valves. Repair or replace as needed. Inspect. Adjust, repair or replace as needed. Inspect. Repair or replace as needed. Inspect. Repair or replace as needed.
Pressure builds too slowly	Engine idle too slow Excessive system leakage Defective air compressor	Inspect. Repair or replace as needed. Inspect system connections and valves. Repair or replace as needed. Inspect. Repair or replace as needed.
Pressure too high	Defective air pressure gauge Poor governor adjustment Air line(s) restricted	Inspect. Repair or replace as needed. Inspect. Adjust, repair or replace as needed. Inspect. Repair or replace as needed.
No brakes	Air line(s) restricted or broken Defective treadle valve	Inspect. Repair or replace as needed. Inspect. Repair or replace as needed.

12.4 Valves

Tractor Protection Valves

Located in the circuitry between the tractor and the trailer, a special valve responds to the trailer air supply knob, or to a broken trailer air line, by cutting off the air supply to the trailer system.

Proportioning Relay (Bobtail) Valve (Optional)

Available as an option, this valve is designed to detect if a trailer is connected to the brake air system. When a trailer is not present, the valve causes the front brakes to do a larger percentage of the work than when a trailer is present.

Connected downstream of the primary reservoir, system air enters its supply port. If no trailer is present, pistons in the valve are repositioned so that, when the pedal is applied, a larger percentage of air goes to the front brakes causing them to assume a greater part of the work of stopping the tractor.

If a trailer is present and the trailer supply valve is opened, a portion of the trailer supply air enters the proportioning valve through its control port. The valve restores its internal pistons to their original positions. Air passes normally through the valve to the rear and trailer brakes.

Quick Release Valves

Each brake chamber connects to its own quick release valve nearby. This valve responds to the release of the foot pedal. The purpose of this valve is to dump the air out of the spring chambers much more quickly than would be possible if the air had to travel back through the supply lines.

Anti-Compounding Valve (Optional)

Also available is an anti-compounding valve that prevents the service brakes from adding to (compounding) the effort exerted by the parking brakes. It protects against brake cracking and damage to the linings.

Double (Two-Way) check Valves

These are used to sense pressure from front and rear, or supply and service, and allow the dominant pressure to actuate the trailer brakes, the stop light switch and release the parking brakes. A two-way quick release valve combines the two functions in a single housing.

12.5 Air Dryer

Description

An air dryer for the brake system is available as optional equipment. In the circuit between the compressor and the reservoir, it removes water vapor from the air. It also removes any oil vapor that may blow by the compressor.

Diagnosis

Components

- Ignition Circuit Breaker 30A
- Ignition Switch

Air Dryer Circuit Diagnosis

Observation	Cause	Action
Inoperative heater	Circuit breaker open	Reset. Repair short as needed. Replace circuit breaker as needed.
	Defective ignition switch	Replace.
	Defective wiring	Inspect connections and wires. Test circuits. Repair or replace as needed.

– D. Error Codes

Description

This section is not applicable for this vehicle.

– E. Schematics

0.1 Air System Circuits

0.1.1 Air Brakes

Components

- ABS Electronic Control Unit
- ABS Modulator Valve
- Air Compressor
- Air Dryer (Optional)
- Air Pressure Governor
- Air Reservoirs (Storage Tanks)
- Brake Chambers
- Check Valves
- Foot Pedal (Treadle) Valve
- Interaxle Lockout (6x4 only, ABS)
- Pressure Relief Valves
- Proportioning Relay Valve
- Quick Release Valves
- Slack Adjusters
- Stoplight Switch
- Tractor Parking Brake Control Valve
- Tractor Protection Valves
- Trailer Air Supply Control Valve
- Two-Way Check and Quick Release Valves

Vehicles intended for road use conform to Federal Motor Vehicle Safety Standard (FMVSS) 121.

This standard specifies test requirements for air brake systems. Semi-trailer tractors must be equipped with an anti-lock brake system (ABS) and meet stopping distance requirements under normal and emergency conditions. ABS is optional on tractors that do not use the roads.

Vehicles intended for road use also conform to applicable Canadian Motor Vehicle Safety Standards (CMVSS).

Air Brake System without ABS

The air brake system without ABS has two air storage tanks, supply and service. There is one pressure gauge on the instrument panel.

TYPICAL AIR SYSTEM WITHOUT ABS

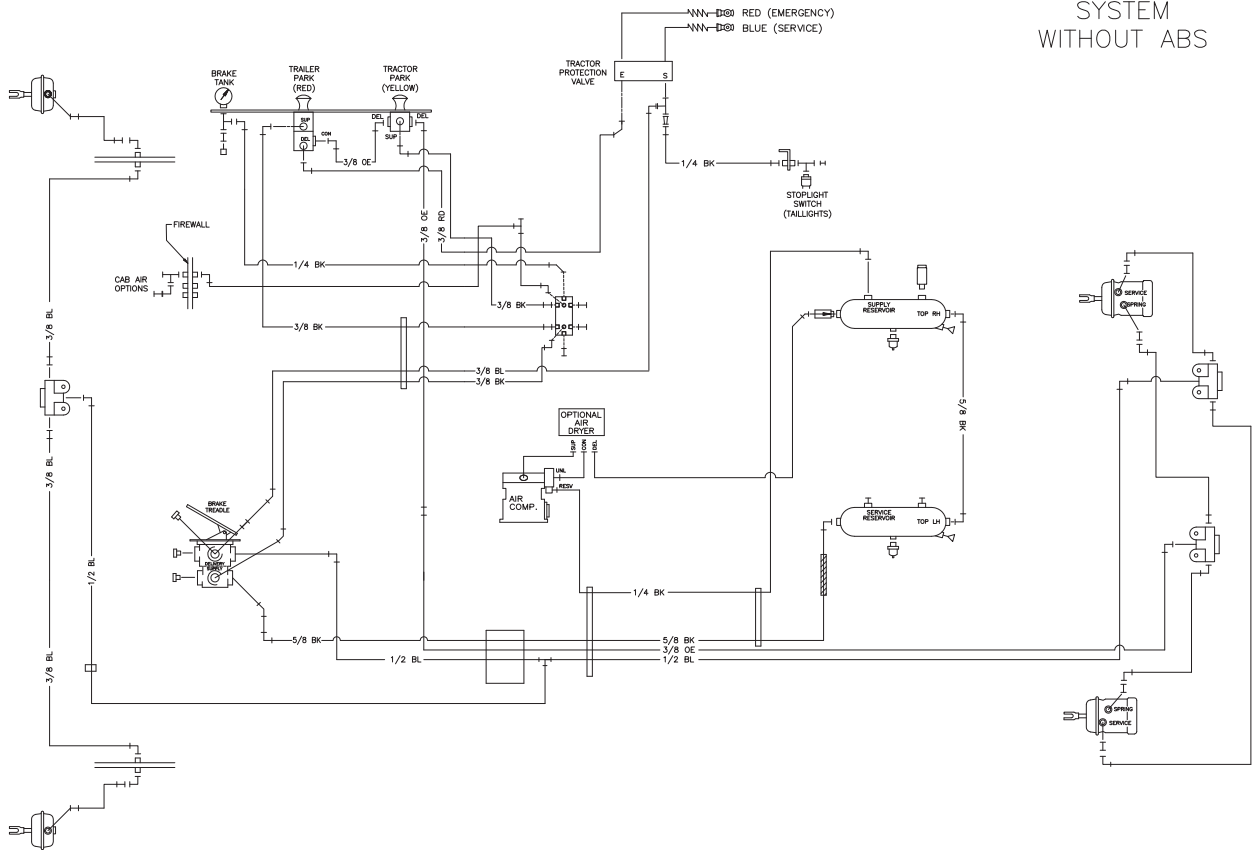

0.1.2 Cab Seating

Air Lines — Driver's Seat

AIR LINES DRIVER'S SEAT

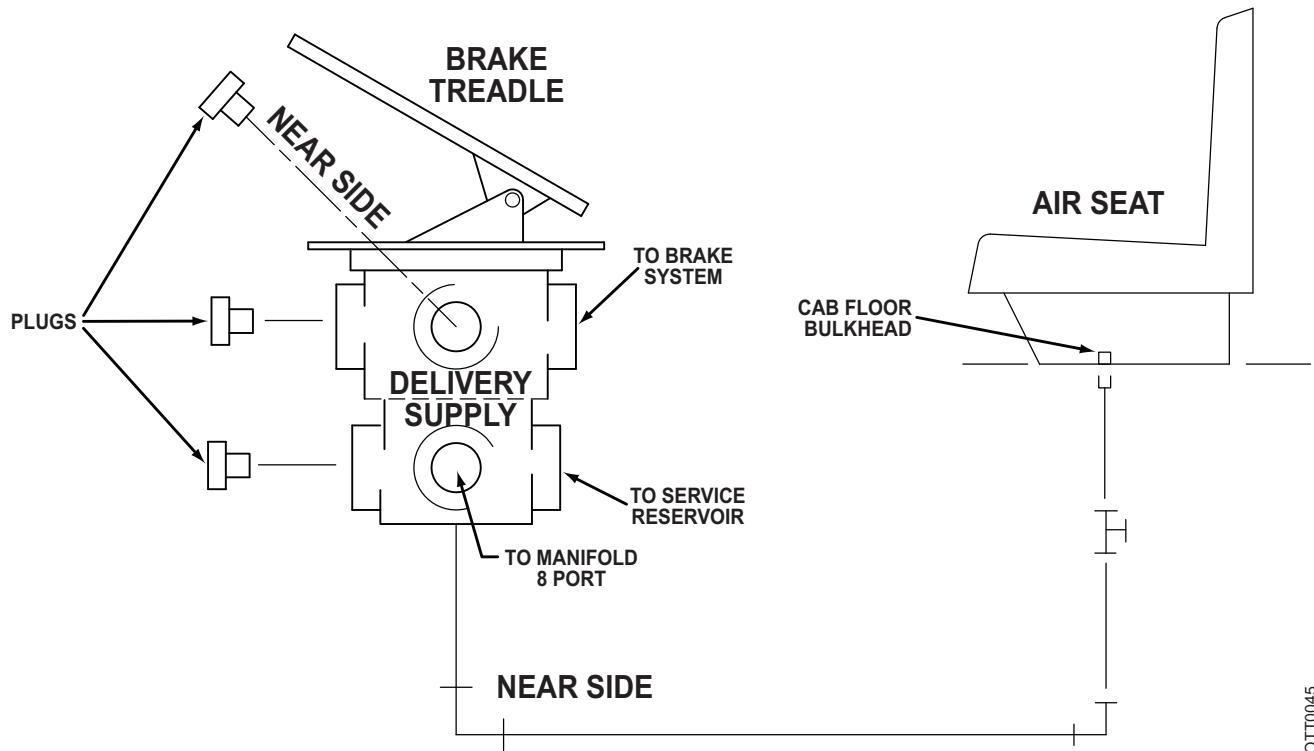

OTT0045

Air Lines — Driver's Seat

Components

- Air Control Valve
- Air Spring
- Air Reservoir

The adjustable driver's seat cushion rides on an air bag. A locking mechanism allows the driver to stop fore and aft chugging if desired. Seating comfort controls are mounted on each side below and in back of the seat cushion.

0.1.3 Cab Suspension

Air Lines — Cab Suspension

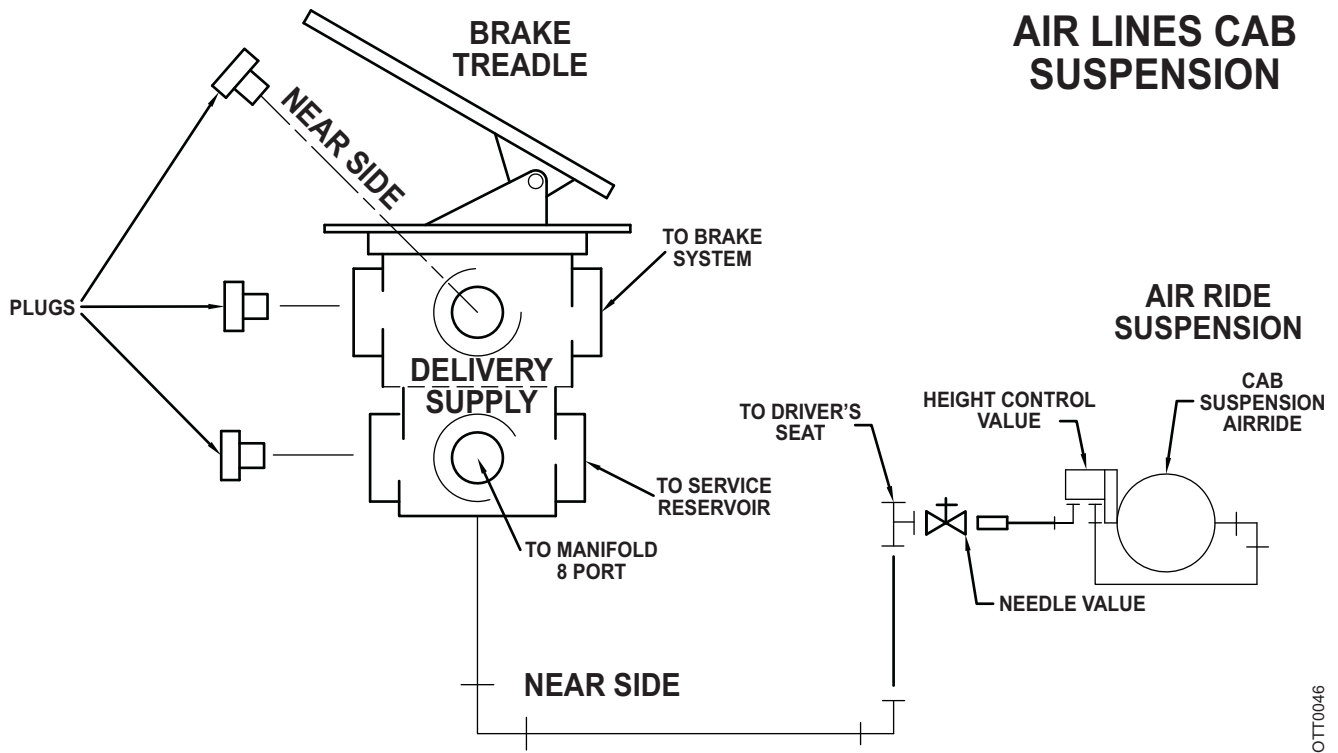

Air Lines — Cab Suspension

Components

- Air Spring
- Height Control Valve
- Latch
- Shock Absorbers

Ride level is adjustable and automatically maintained. Two shock absorbers react with the air spring to maintain a soft, smooth ride. A rubber bumper prevents the cab from striking the rails.

0.1.4 Fifth-Wheel Coupling

Air Lines — Fifth-Wheel Latch

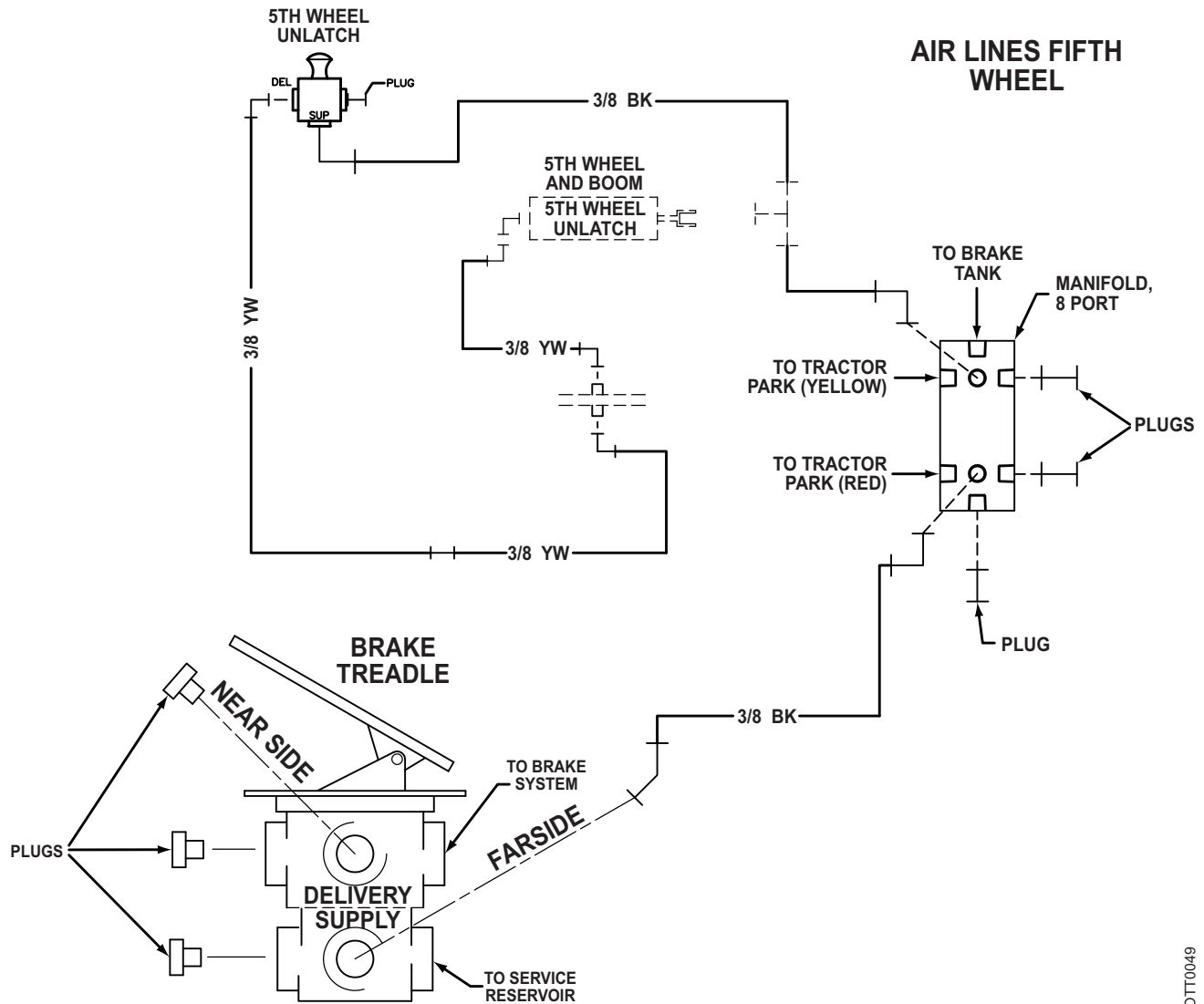

Air Lines — Fifth-Wheel Latch

Components

- Air Control Valve
- Air Cylinder
- Air Reservoir

Pressing the control valve button on the instrument panel opens the latch. The button is spring-loaded and normally closed. Once opened, the latch remains open until closed by a trailer king pin.

OTT0049

0.2 Hydraulic System Circuits

Hydraulic Systems

One electric motor with integral pump and one hydraulic fluid reservoir are shared by the fifth-wheel boom, cab tilt and power steering systems. Each system operates independently. The motor is mounted on the transmission housing. All fluid passes through a filter mounted beside the reservoir.

0.2.1 Cab Tilt

Hydraulic Lines — Cab Tilt

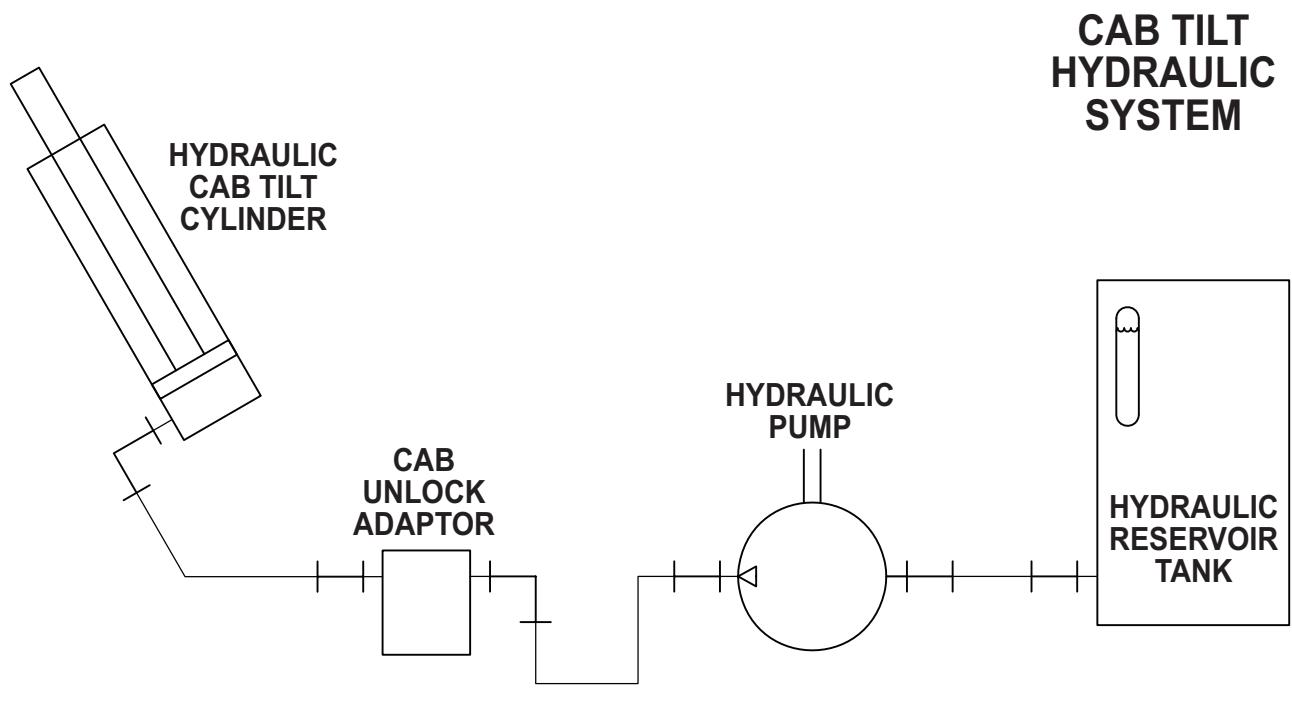

Hydraulic Lines — Cab Tilt System

Components

- Control Switch
- Hydraulic Cylinder
- Lanyard
- Safety Prop
- Solenoid

For tilting the cab, the motor is controlled by a switch on the rail. A lanyard near the switch allows the operator to unlatch the safety prop prior to up or down movement.

0.2.2 Fifth-Wheel Boom

Hydraulic Lines — Fifth-Wheel Boom

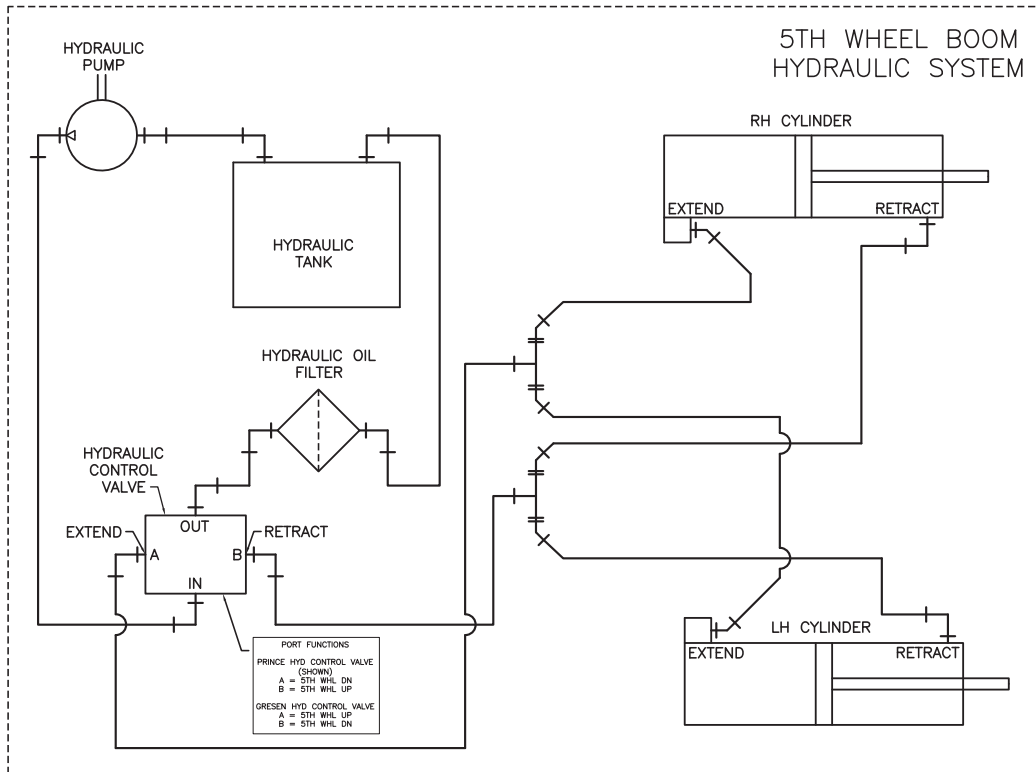

Hydraulic Lines — Fifth-Wheel Boom

Components

Boom

Control Valve

Hydraulic Cylinders

Hydraulic Relief Valve

Although engine speed controls the speed of the double-acting cylinders, restrictors slow the downward motion.

0.2.3 Power Steering

Hydraulic Lines — Power Steering

POWER STEERING HYDRAULIC SYSTEM

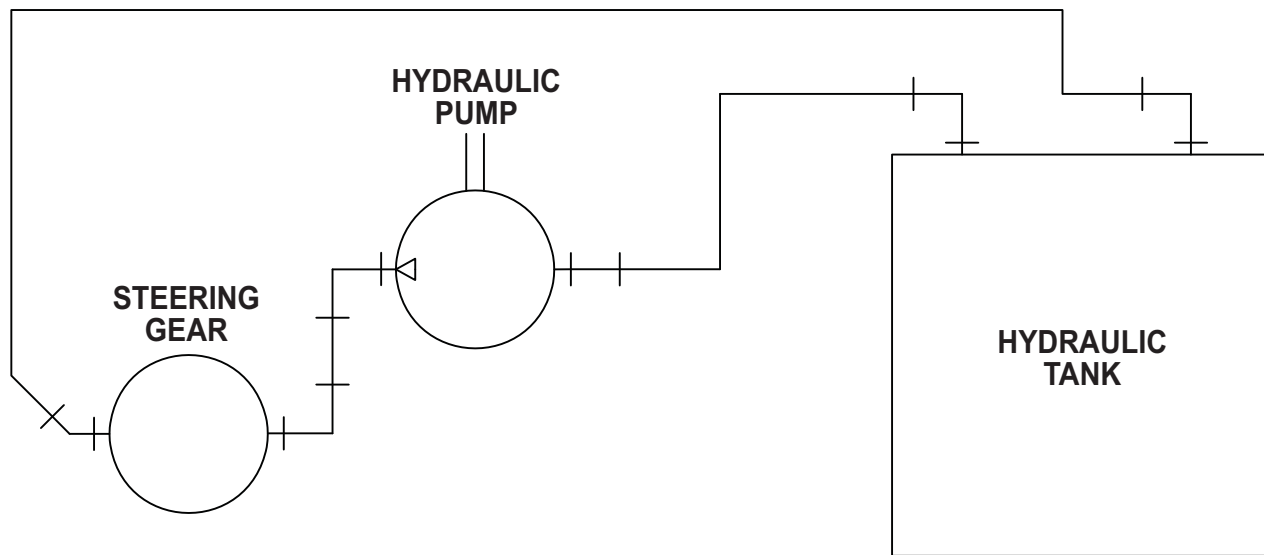

OTT0050

Hydraulic Lines — Power Steering System

Components

Integral Steering Gear

The power steering system shares the hydraulic fluid reservoir with the cab tilt and boom lift systems.

0.2.4 Optional Hydrostatic Steering

Hydraulic Lines — Hydrostatic Steering

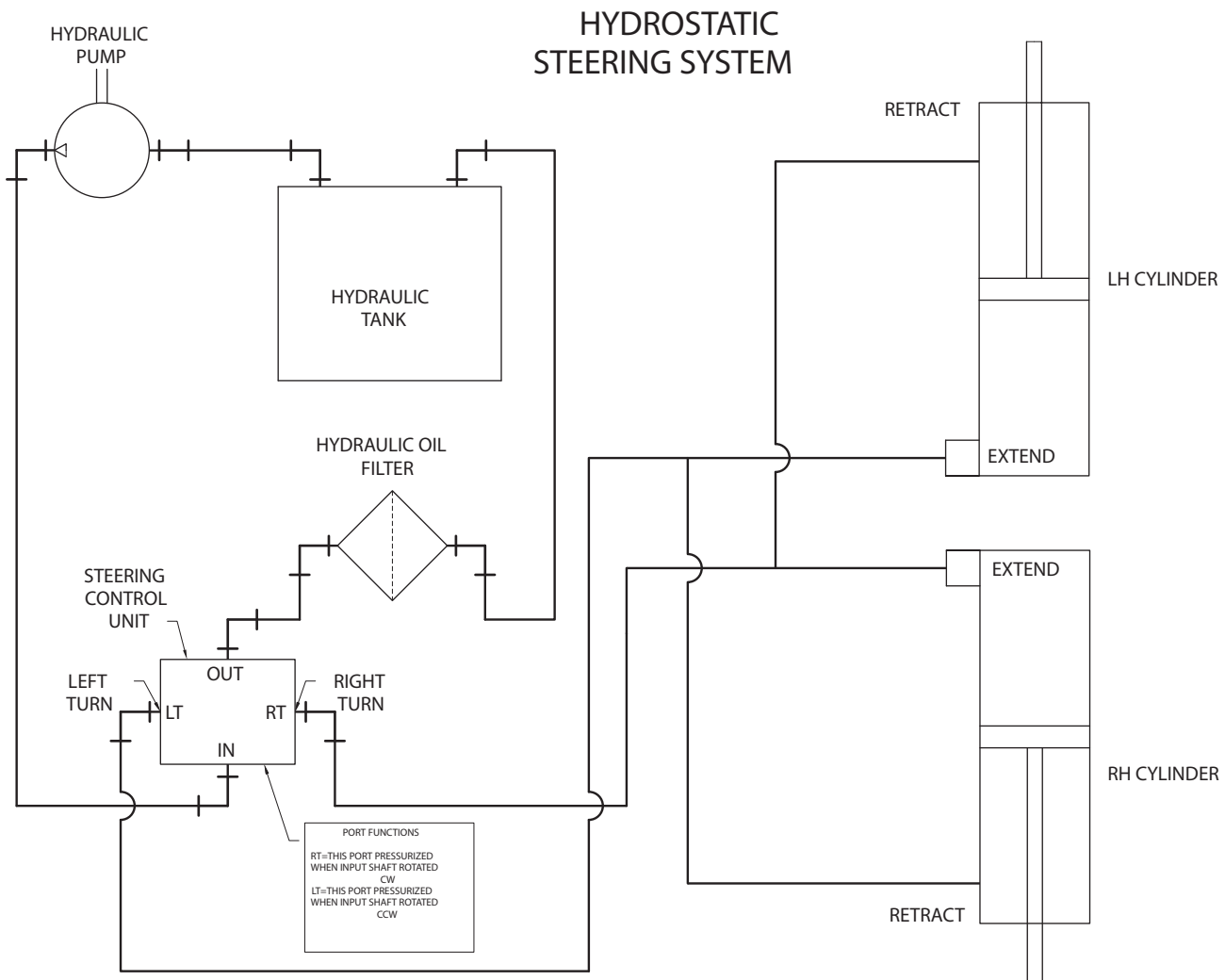

Components

Alternator

Batteries

Circuit Breaker — Ignition Switch (Cab Accessory Fuse Panel)

Fuse — Gauge (Cab Accessory Fuse Panel)

Ignition Relay

Ignition Switch

Neutral Start Relay

Oil Pressure (Hourmeter) Switch

Start Cutout #1 Relay

Start Cutout #2 Relay

Start Solenoid

Starter Motor with Solenoid

0.3.2 Cab Accessory Components

Wire Color Codes

BE = Blue

BK = Black

BN = Brown

GN = Green

OE = Orange

PE = Purple

PK = Pink

RD = Red

TN = Tan

WE = White

YW = Yellow

Anti-lock Braking System (ABS)

For information on the anti-lock braking system, refer to the vendor's service manual.

Heater and Air Conditioning

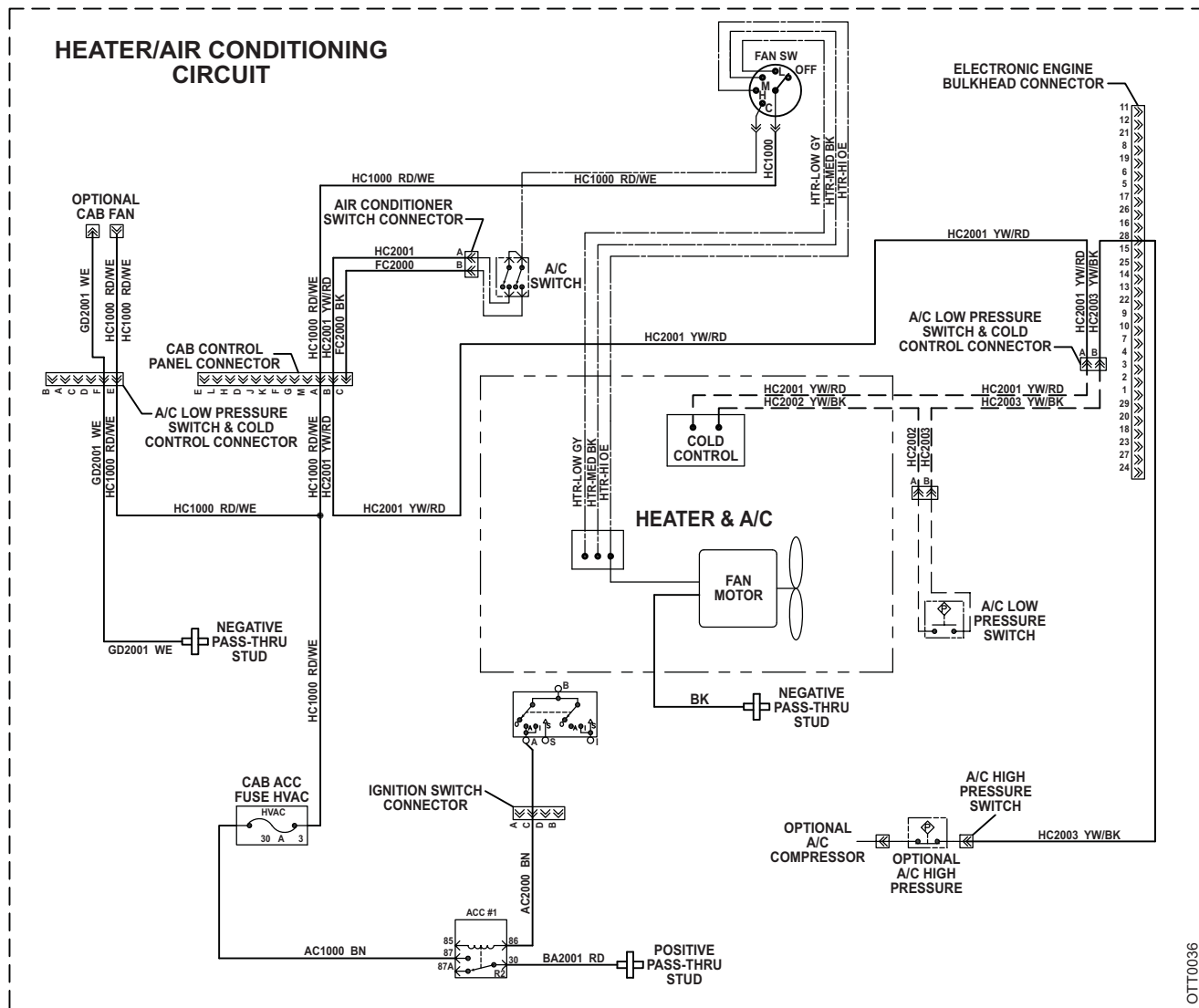

Heating and Air Conditioning Circuits

Components

- Accessory Relay #1
- Air Conditioner Switch
- Cab Fan (Optional)
- Cold Control (AC Optional)
- HVAC Fan Motor
- Fan Switch
- Fuse — HVAC (Cab Accessory Fuse Panel)
- Ignition Switch

Air conditioning is optional equipment.

Heated and Motorized (Optional)

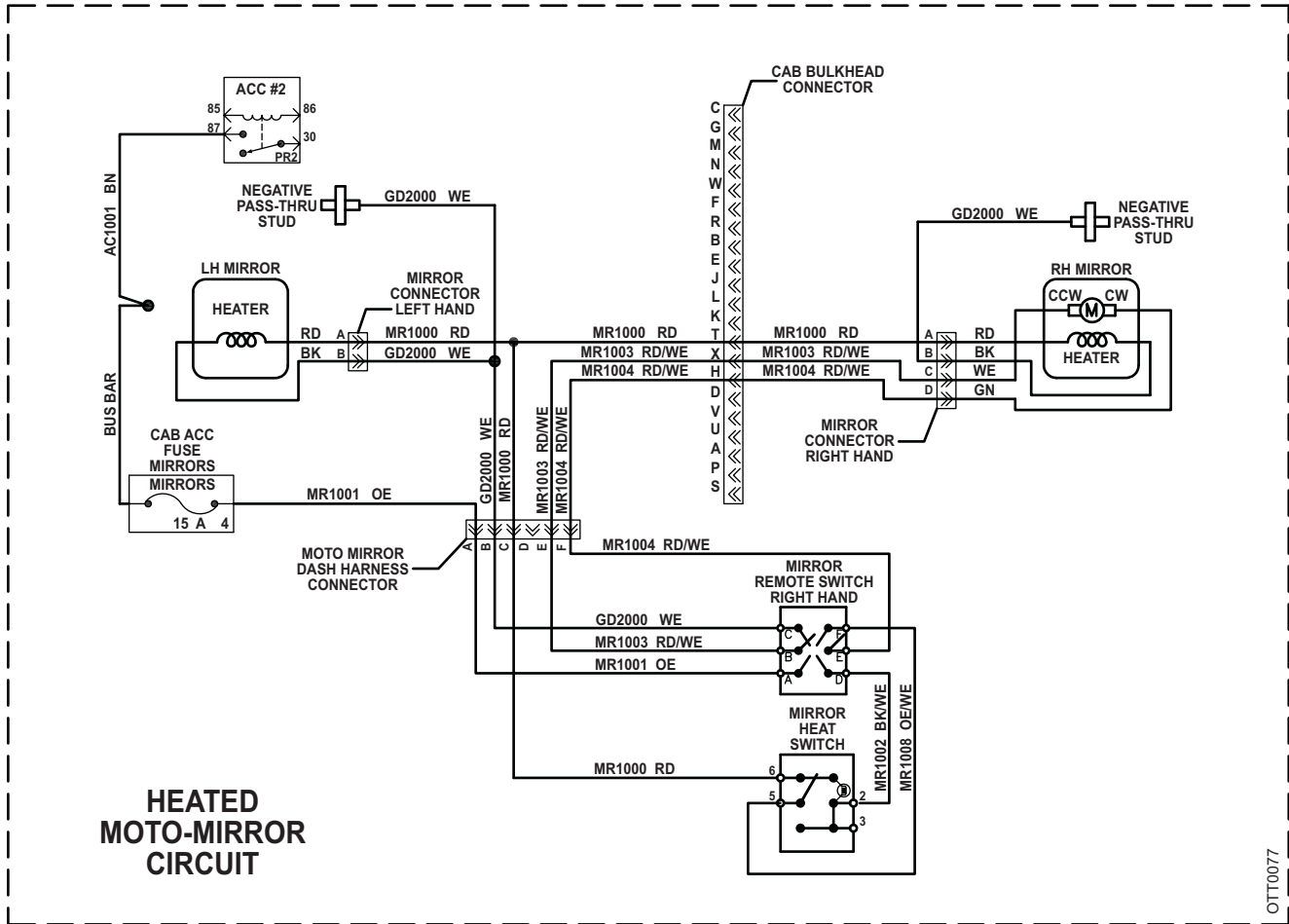

Heated and Motorized Mirror Circuit

Components

- Circuit Breaker — Optional Accessory
- Heater Switch
- Left-Hand Mirror Heater
- Left-Hand Mirror Motor
- Left-Hand Motor Switch
- Right-Hand Mirror Heater
- Right-Hand Mirror Motor
- Right-Hand Motor Switch

An indicator lamp illuminates when the mirror heater is active. The ignition switch must be **On** to use the mirror heater and motor.

Radio (Optional)

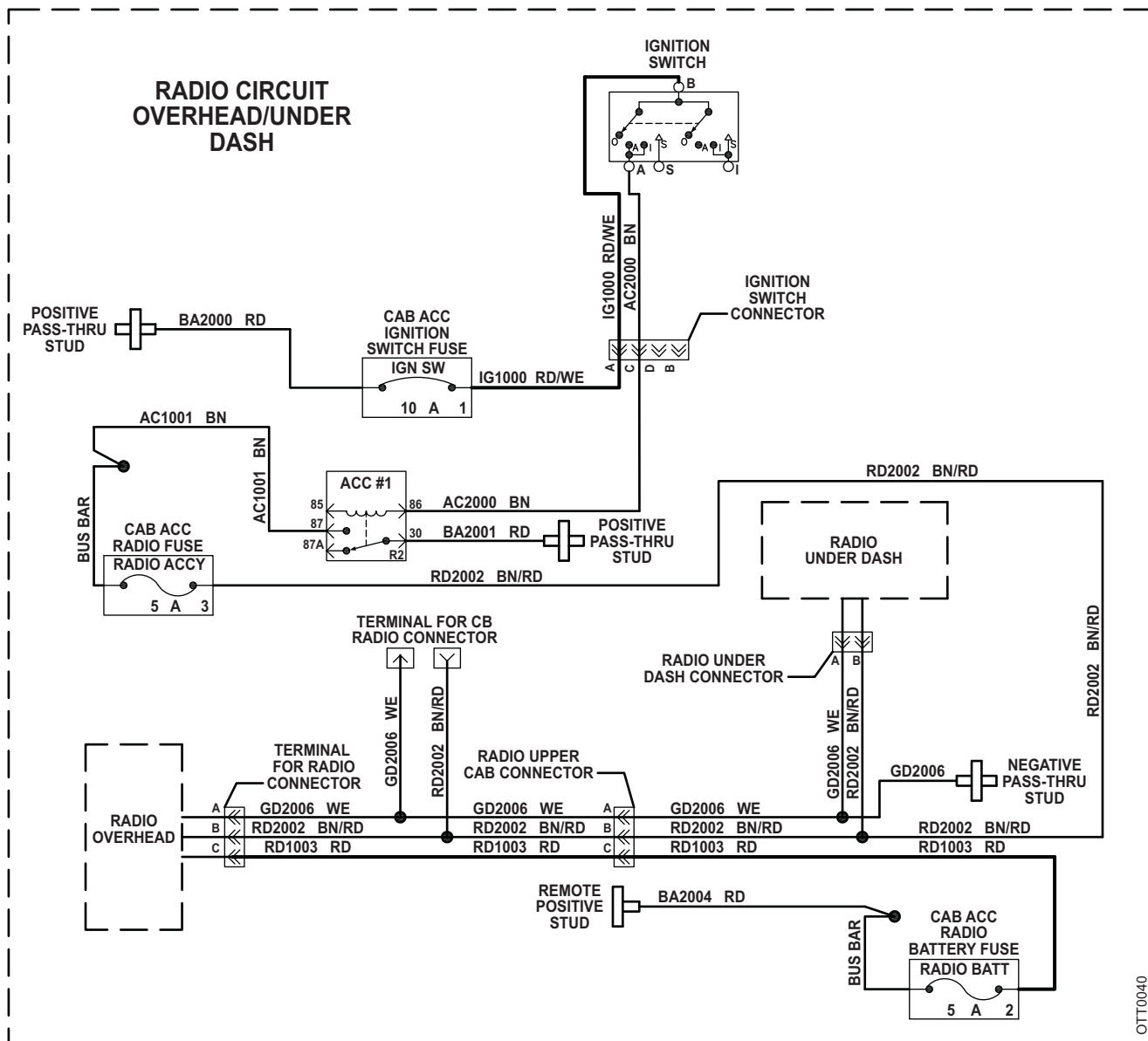

OTT0040

Radio Circuit Overhead/Under Dash

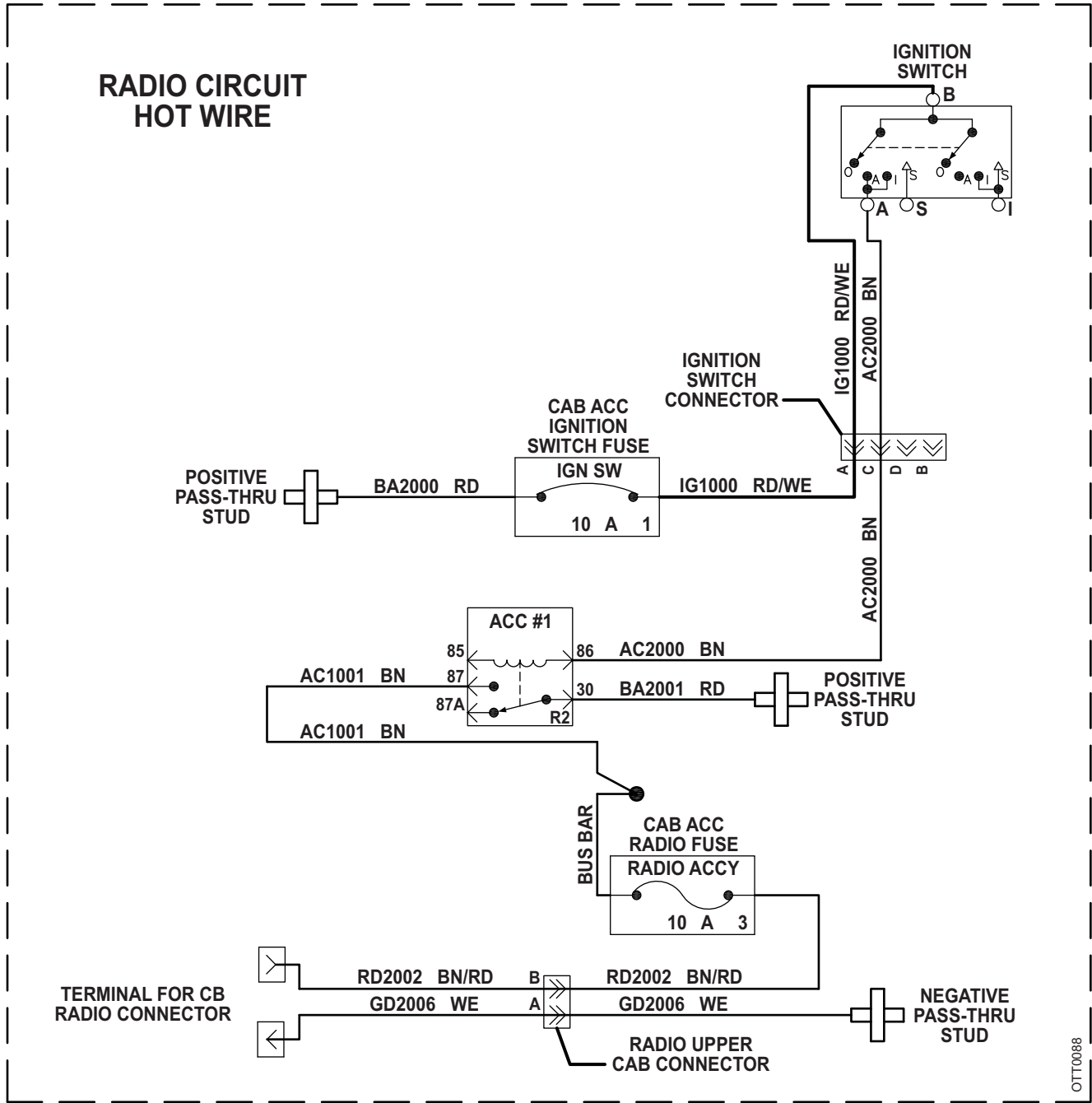

OTT0088

Radio Circuit — Hot Wire

Components

- Accessory Relay #1
- Circuit Breaker — Radio Battery (Cab Accessory Fuse Panel)
- Fuse — Ignition Switch (Cab Accessory Fuse Panel)
- Fuse — Radio (Cab Accessory Fuse Panel)
- Ignition Switch

The ignition switch must be **On** to use the radio.

Windshield Washer (Optional)

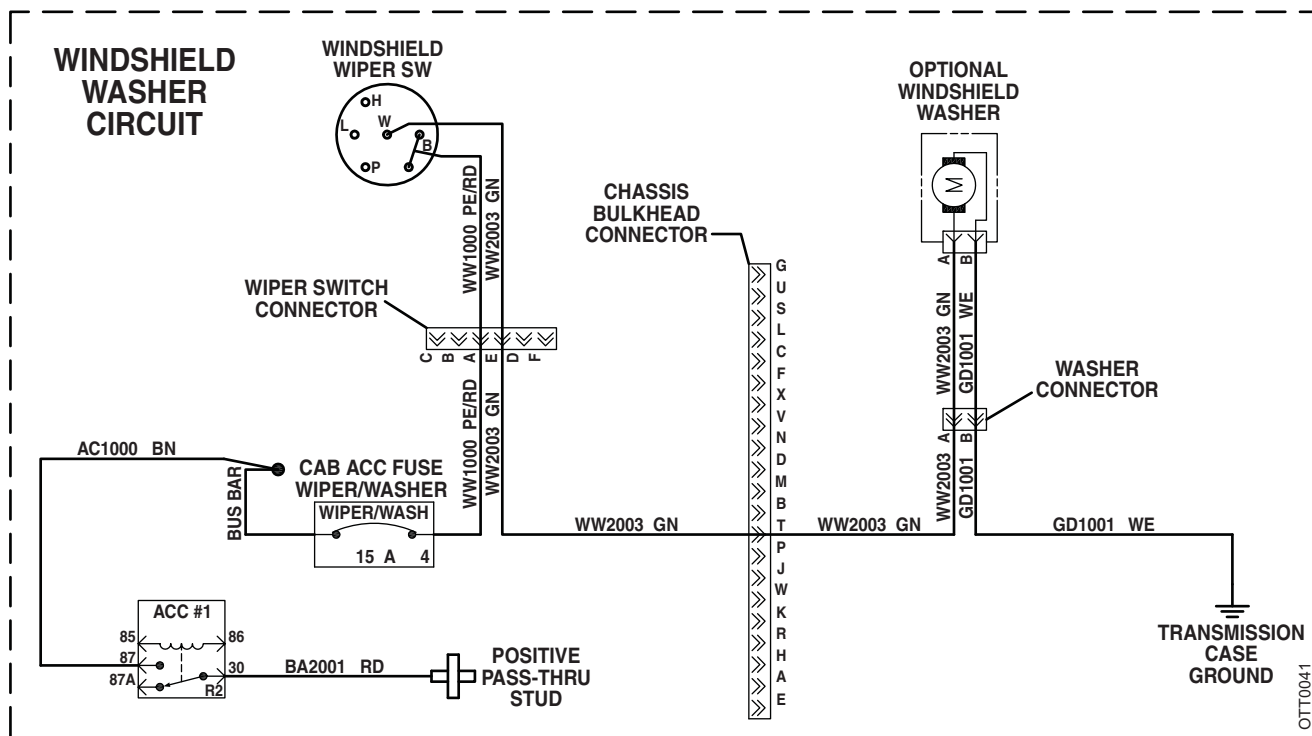

Windshield Washer Circuit

Components

- Accessory Relay #1
- Circuit Breaker — Wiper/Washer (Cab Accessory Fuse Panel)
- Windshield Washer Motor
- Windshield Wiper Switch

The ignition switch must be **On** to use the windshield washer.

Windshield Wiper

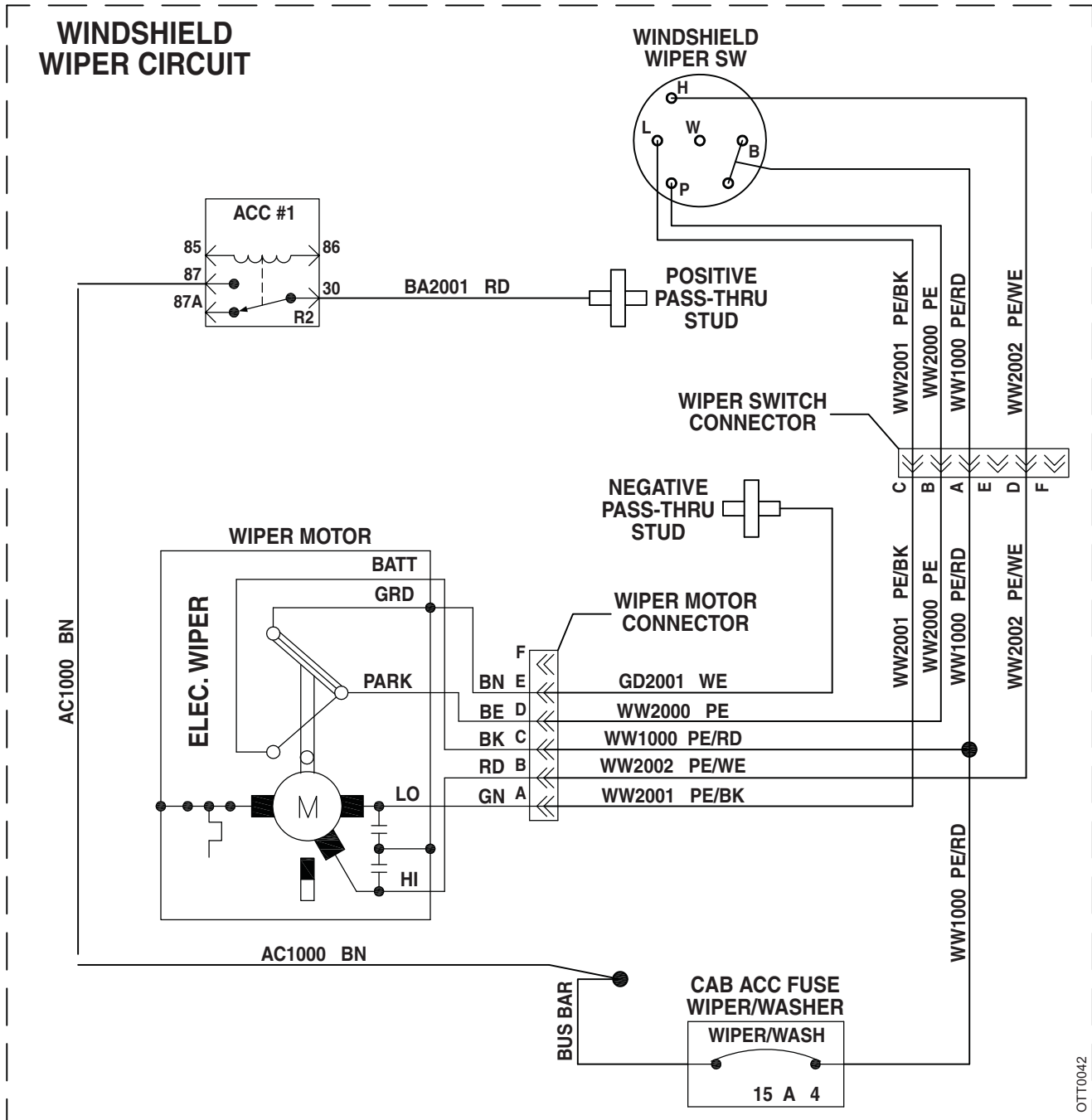

Windshield Wiper Circuit

Components

- Accessory Relay #1
- Circuit Breaker — Wiper/Washer (Cab Accessory Fuse Panel)
- Windshield Wiper Motor
- Windshield Wiper Switch

The ignition switch must be **On** to use the windshield wiper.

0.3.3 Cab Instrumentation

Air Pressure Gauge Lighting

Components

- Gauge
- Gauge (Second Service Tank)
- Gauge Lamp
- Gauge Lamp (Second Service Tank)
- Headlight Switch
- Panel Dimmer Switch (Optional)

Vehicles equipped with ABS have two service tanks and a pressure gauge for each one.

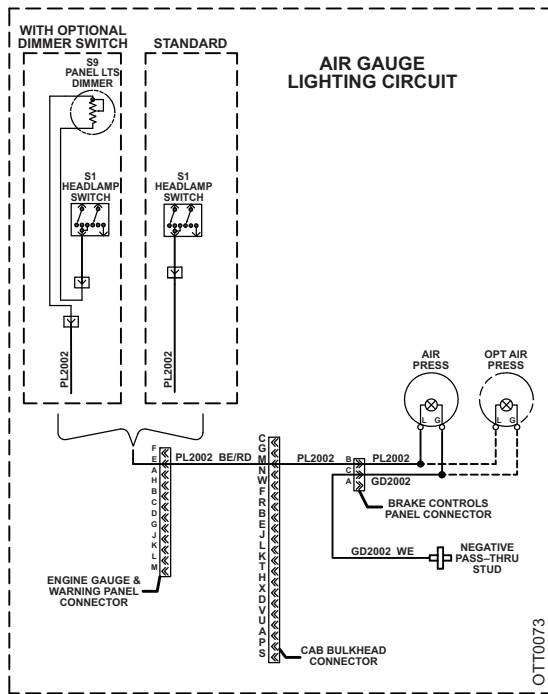

Air Pressure Gauge Lighting Circuit

Components

- Alternator
- Ammeter
- Ammeter Lamp
- Ammeter Shunt
- Batteries
- Headlight Switch
- Light Bar
- Panel Dimmer Switch (Optional)
- Starter with Solenoid

Engine Coolant Temperature Gauge

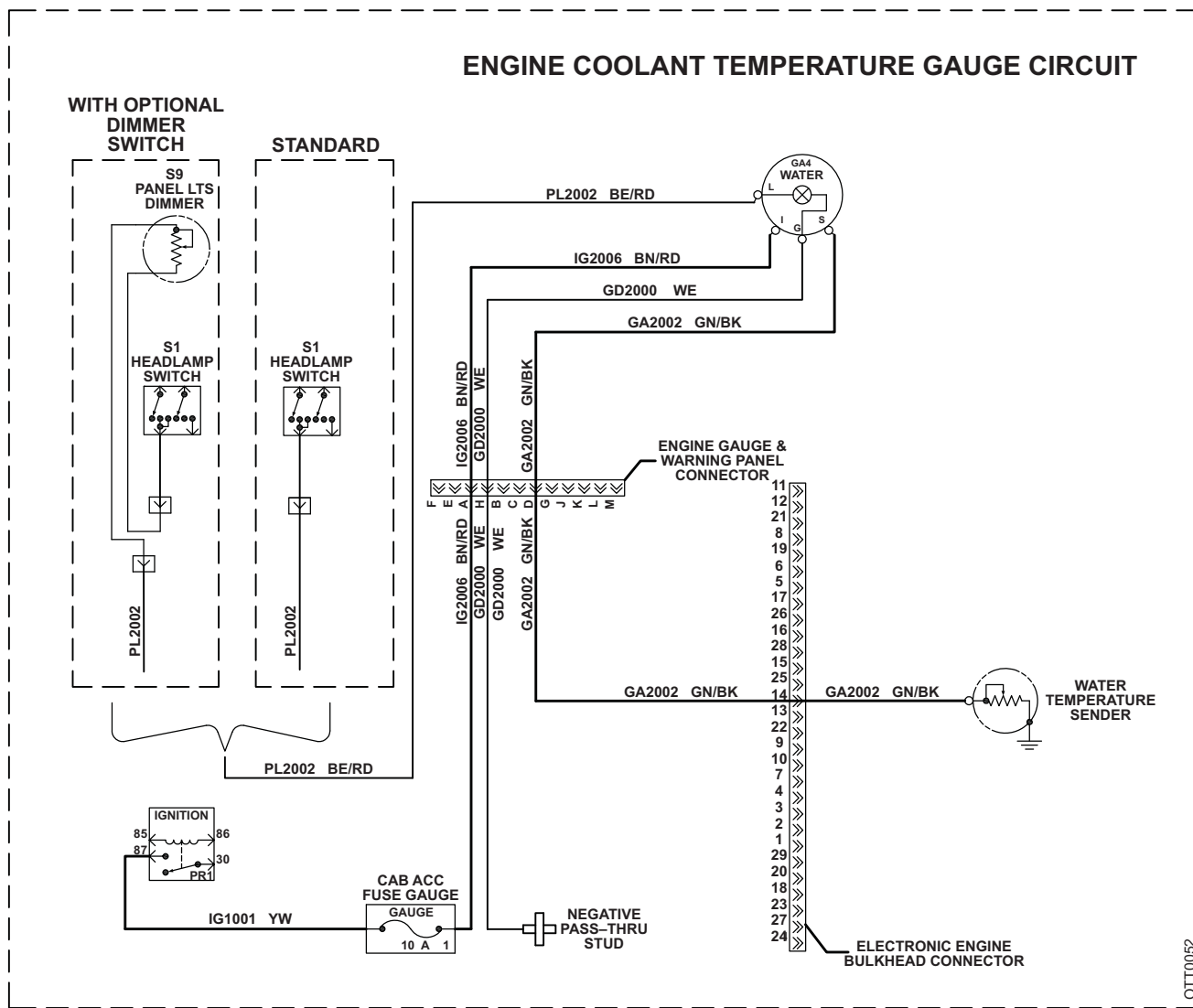

Engine Coolant Temperature Gauge Circuit

Components

- Coolant Temperature Gauge
- Fuse — Gauge (Cab Accessory Fuse Panel)
- Gauge
- Gauge Lamp
- Headlight Switch
- Ignition Relay
- Panel Dimmer Switch (Optional)
- Sender (Water Temperature — Variable Resistance)

The engine coolant temperature gauge reads in degrees Fahrenheit (°F).

Engine Hourmeter

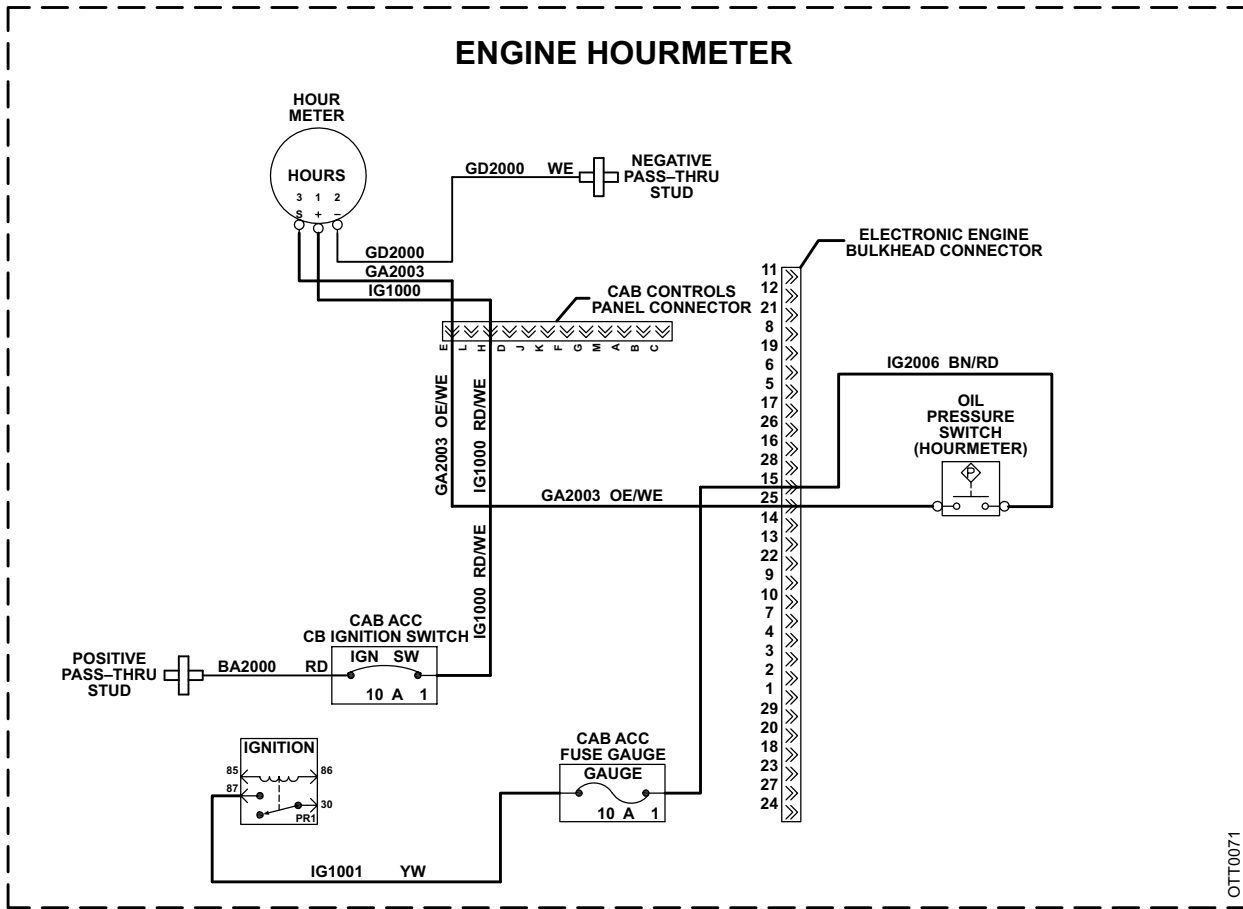

Engine Hourmeter Circuit

Components

Fuse — Gauge (Cab Accessory Fuse Panel)

Gauge

Gauge Lamp

Headlight Switch

Ignition Relay

Panel Dimmer Switch (Optional)

Sender (Oil Pressure — Variable Resistance)

The engine oil pressure gauge reads in pounds per square inch (PSI).

Low Air Warning Alarm

Components

- Fuse — Gauge (Cab Accessory Fuse Panel)
- Ignition Relay
- Low Air Alarm Buzzer
- Low Air Switch
- Low Air Switch (Optional)

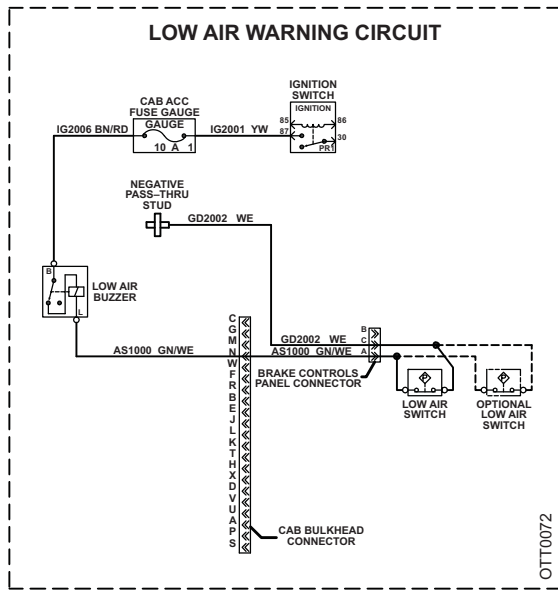

Low Air Warning Alarm Circuit

Speedometer (Optional)

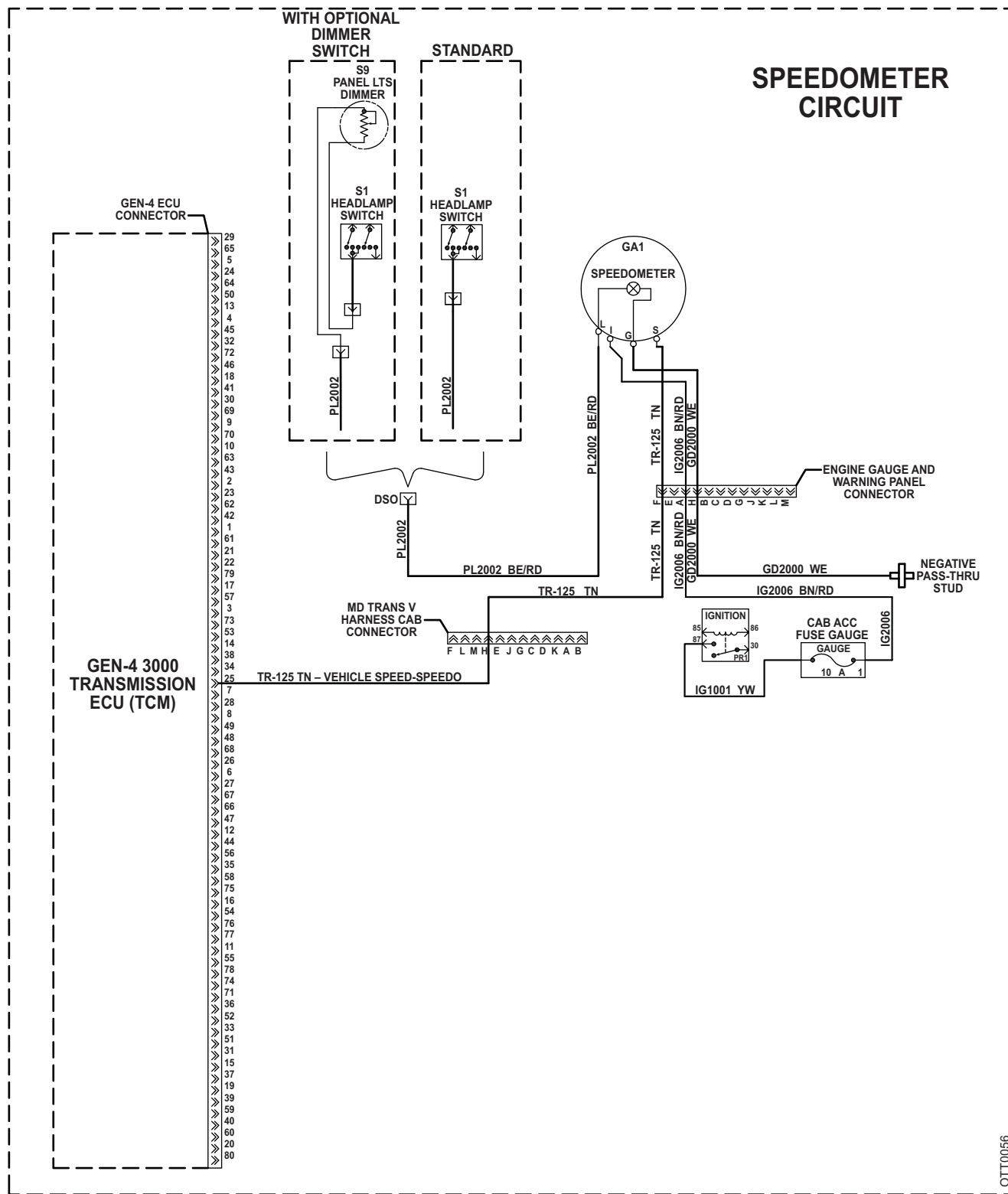

Speedometer Circuit

Components

- Fuse — Gauge (Cab Accessory Fuse Panel)
- Gauge (Speedometer)
- Gauge Lamp
- Headlight Switch
- Ignition Relay
- Panel Dimmer Switch (Optional)

Some tractor speedometers may also display the total distance traveled.

The speedometer is affected by DIP switch settings, tire size, gear ratios and the source of pulse generation.

Tachometer (Optional)

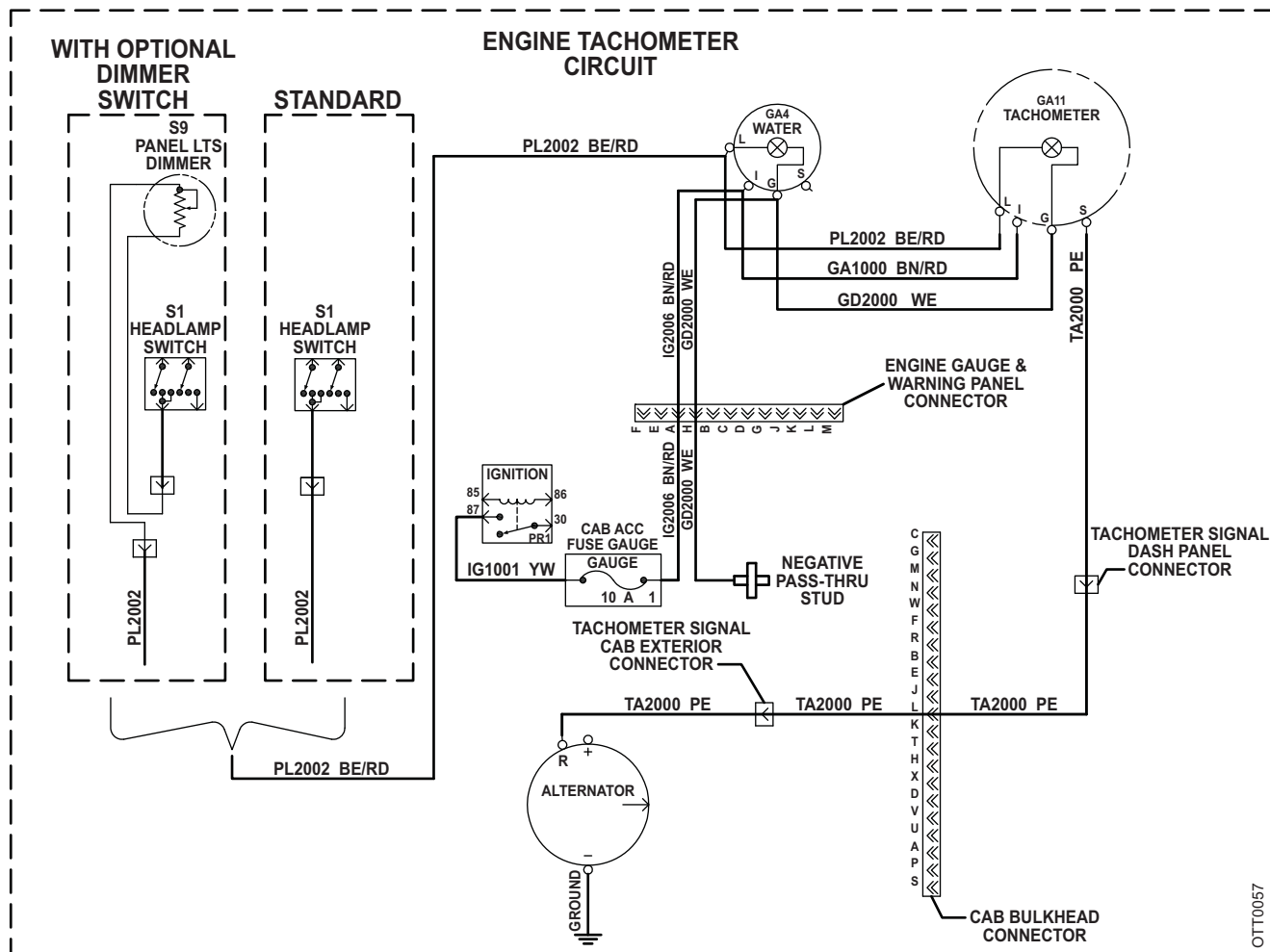

Tachometer Circuit

Components

- Alternator
- Fuse — Gauge (Cab Accessory Fuse Panel)
- Ignition Relay
- Gauge (Tachometer)
- Gauge Lamp (Tachometer)
- Gauge Lamp (Water Temperature)
- Gauge (Water Temperature)
- Headlight Switch
- Panel Dimmer Switch (Optional)

The tachometer displays crankshaft revolutions per minute (RPM).

Transmission Oil Temperature Gauge

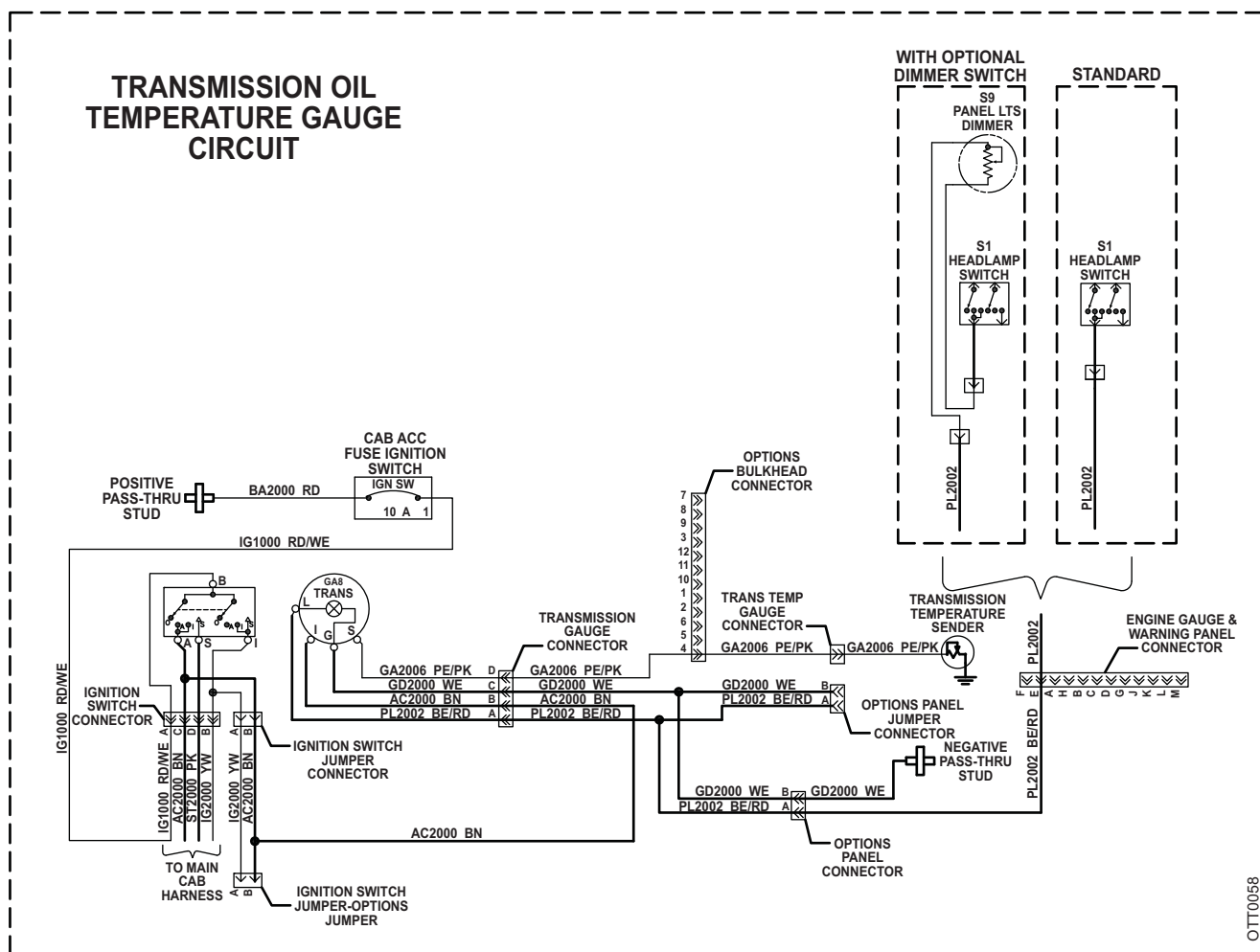

Transmission Oil Temperature Gauge Circuit

Components

Circuit Breaker — Ignition Switch (Cab Accessory Fuse Panel)

Gauge Lamp

Headlight Switch

Ignition Switch

Panel Dimmer Switch (Optional)

Sender (Transmission Oil Temperature)

Transmission Oil Temperature Gauge

The transmission oil temperature gauge reads in degrees Fahrenheit (°F).

Voltmeter

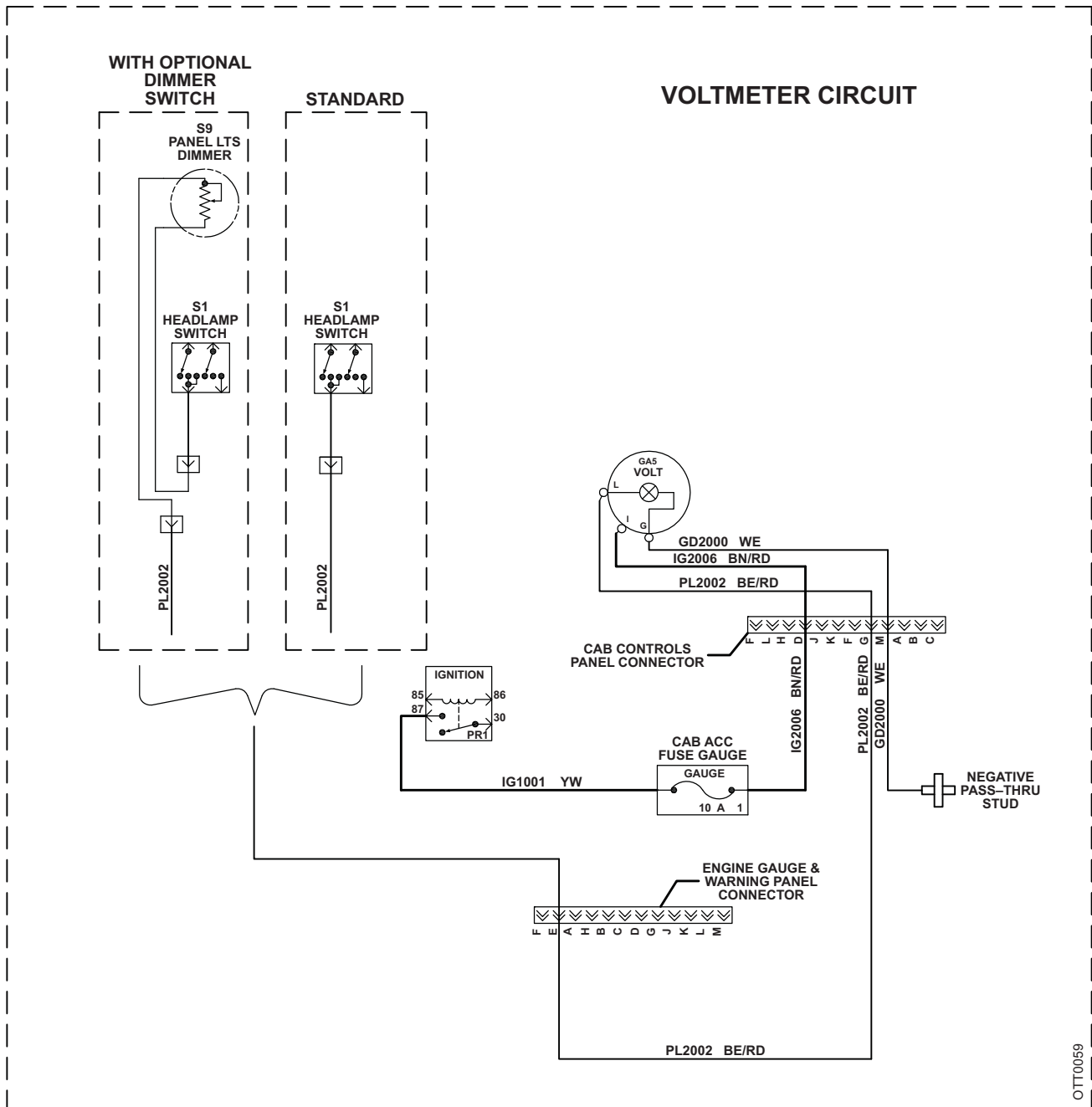

Voltmeter Circuit

Components

- Fuse — Gauge (Cab Accessory Fuse Panel)
- Gauge Lamp
- Headlight Switch
- Ignition Relay
- Panel Dimmer Switch (Optional)
- Voltmeter

OTT0059

The voltmeter detects the voltage at the accessory terminal on the ignition switch.

0.3.4 Chassis Circuits

Air Dryer (Optional)

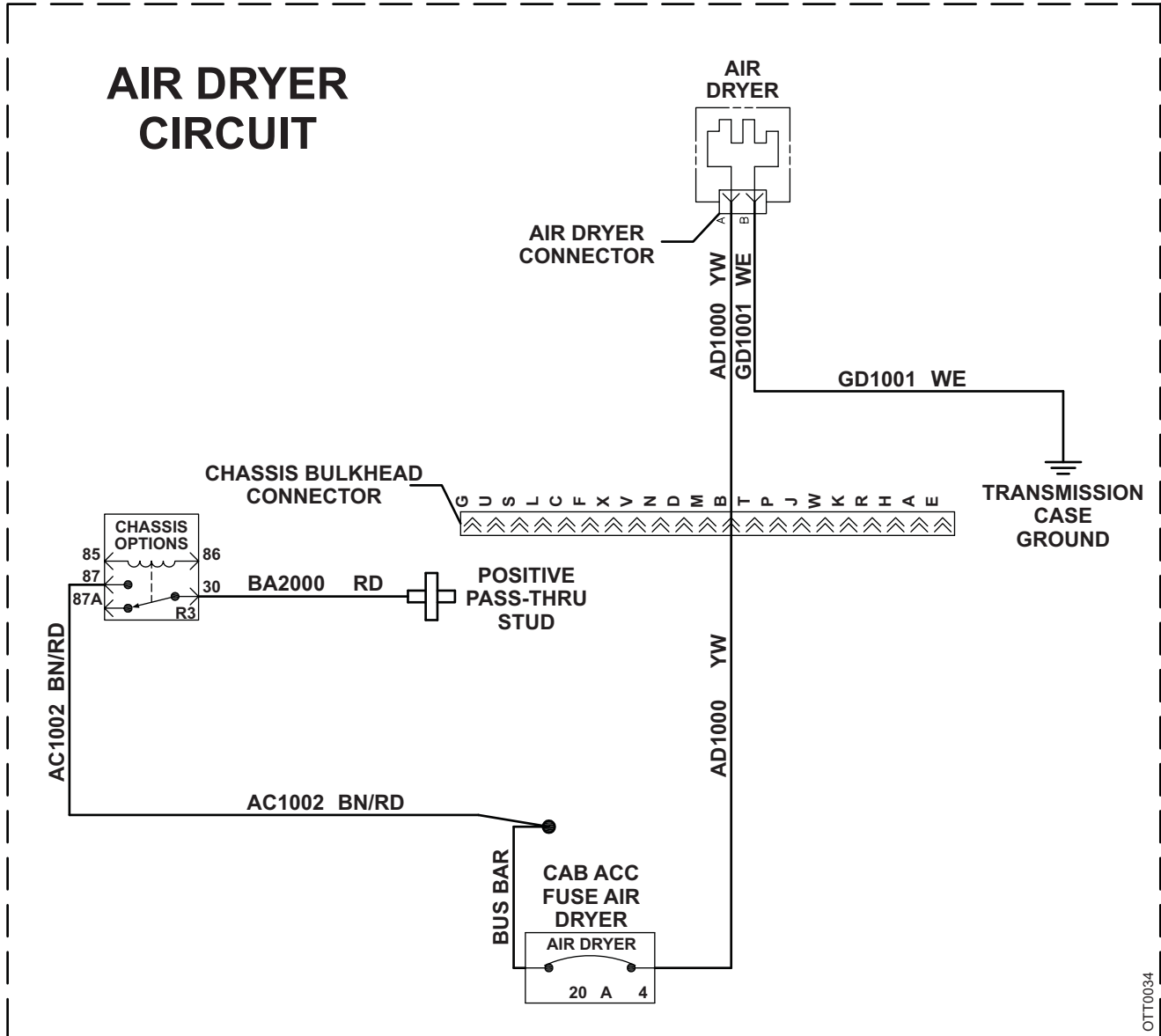

Air Dryer Circuit

Components

- Air Dryer
- Chassis Options Relay
- Circuit Breaker — Air Dryer (Cab Accessory Fuse Panel)

Cab Tilt Pump

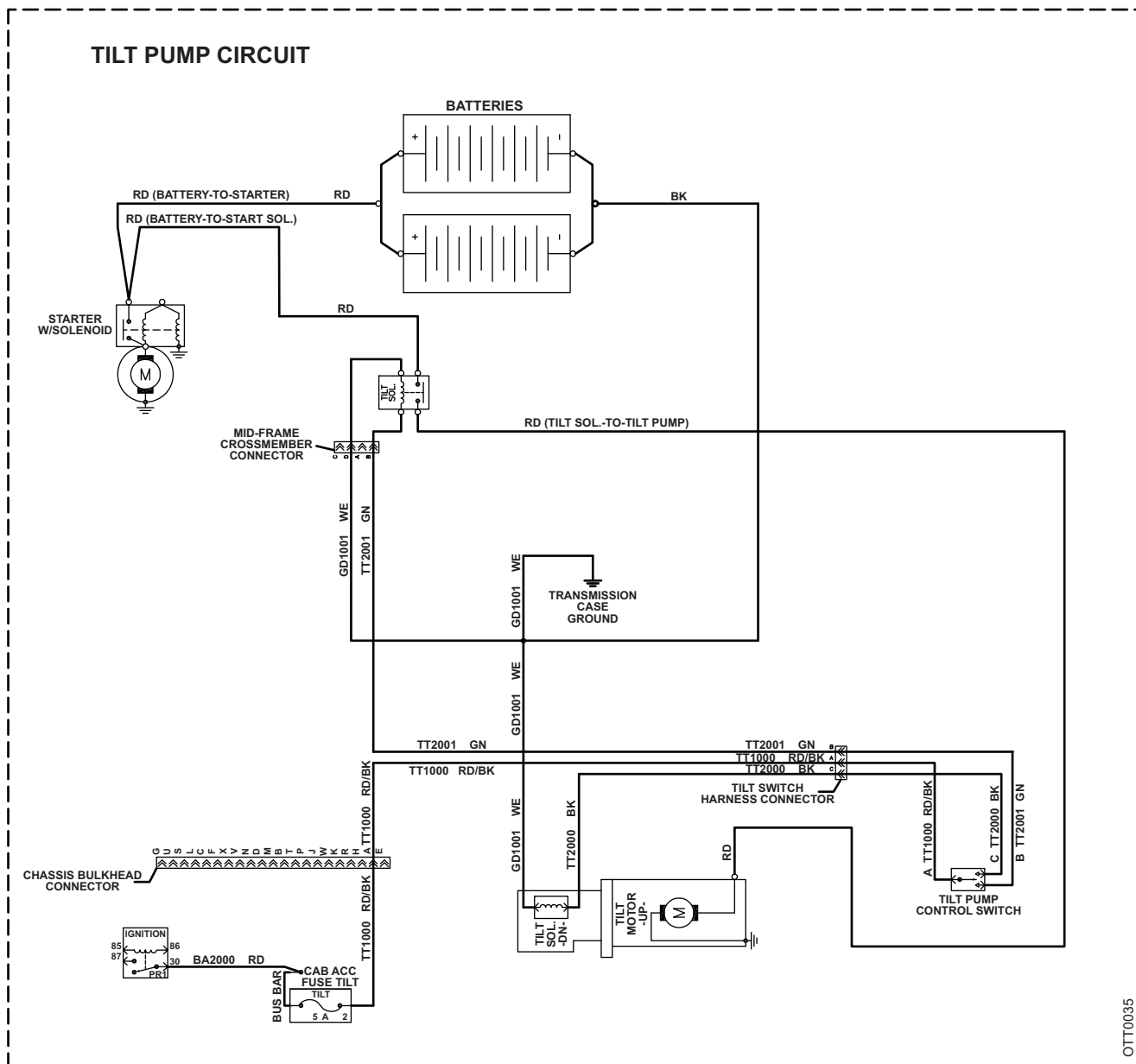

OTT0035

Cab Tilt Pump Circuit

Components

- Batteries
- Fuse — Tilt (Cab Accessory Fuse Panel)
- Ignition Relay
- Starter with Solenoid
- Tilt Pump Control Switch
- Tilt Pump Motor (Up)
- Tilt Solenoid (Down)
- Tilt Solenoid to Pump

0.3.5 Lighting Circuits (Cab and Chassis)

Backup Light and Alarm

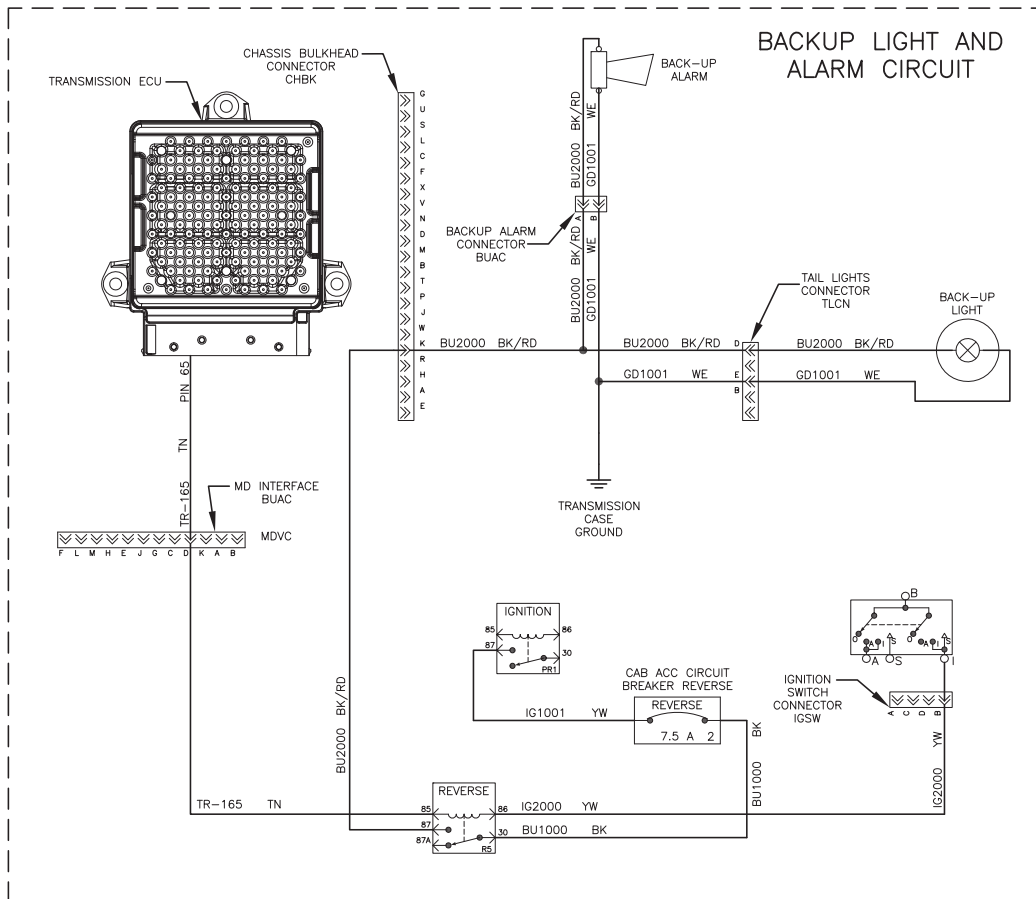

Backup Light and Alarm Circuit

Components

- Backup Alarm
- Backup Lamp
- Circuit Breaker — Reverse (Cab Accessory Fuse Panel)
- Ignition Relay
- Reverse Relay
- Transmission Case Ground

The backup lamp illuminates and the alarm sounds when the transmission is shifted to reverse.

Beacon/Strobe Light

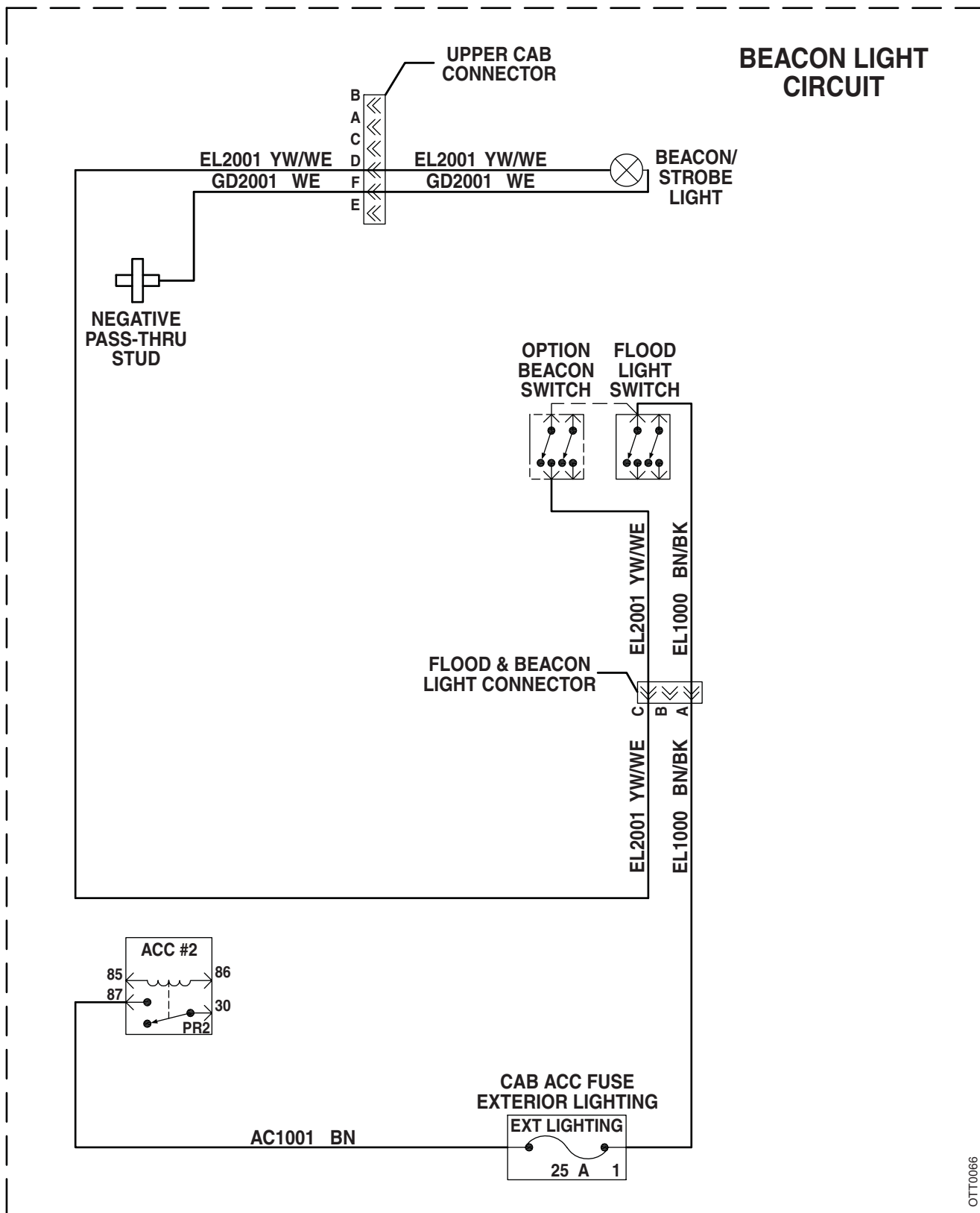

Beacon/Strobe Light Circuit

Components

- Accessory Relay #2
- Beacon/Strobe Lamp
- Fuse — Exterior Lighting (Cab Accessory Fuse Panel)
- Beacon Light Switch (Optional)
- Flood Light Switch

The flood light switch is mounted on the instrument panel.

Clearance Lights

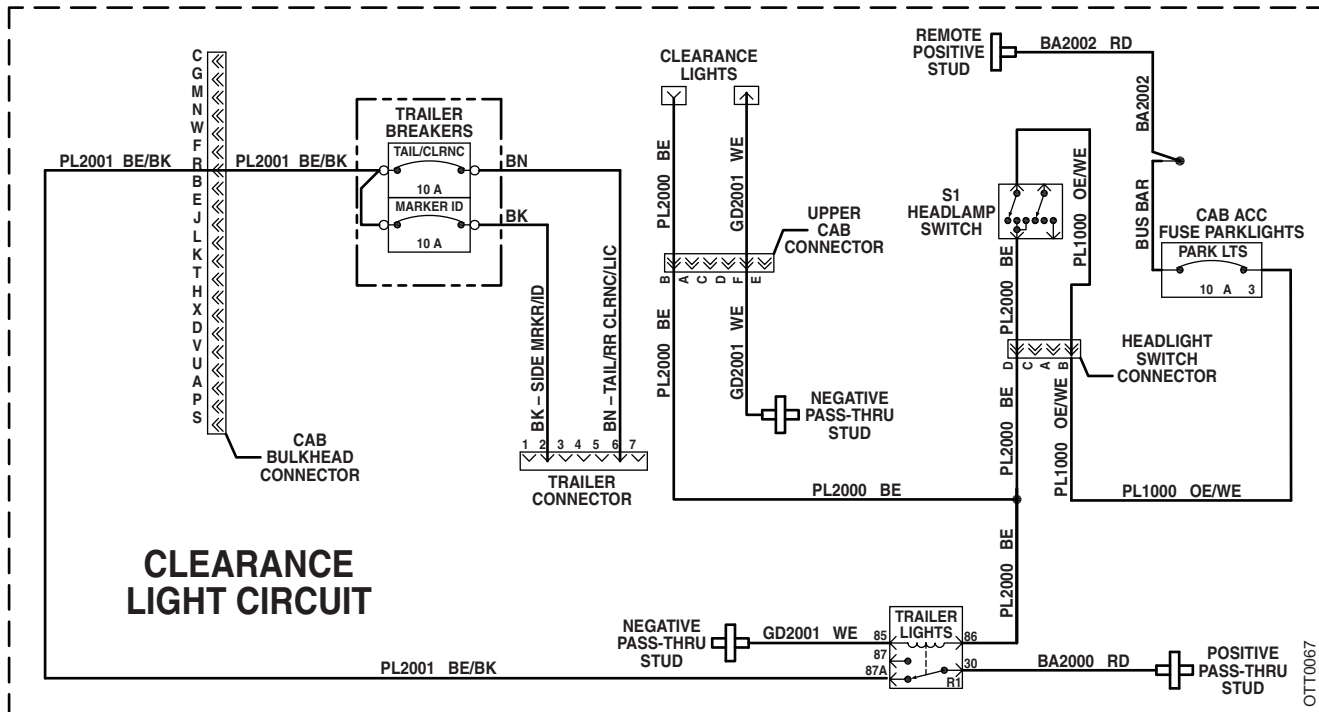

Clearance Lights Circuit

Components

- Circuit Breaker — Parking Lights (Cab Accessory Fuse Panel)
- Circuit Breaker — Marker/ID Lights (Trailer Breakers)
- Circuit Breaker — Tail/Clearance Lights (Trailer Breakers)
- Cab Clearance Lamps
- Headlight Switch
- Trailer Lights Relay

Double Face Turn/Marker Lights are standard equipment on vehicles that meet FMVSS and CMVSS requirements.

Daytime Running Lights (Optional)

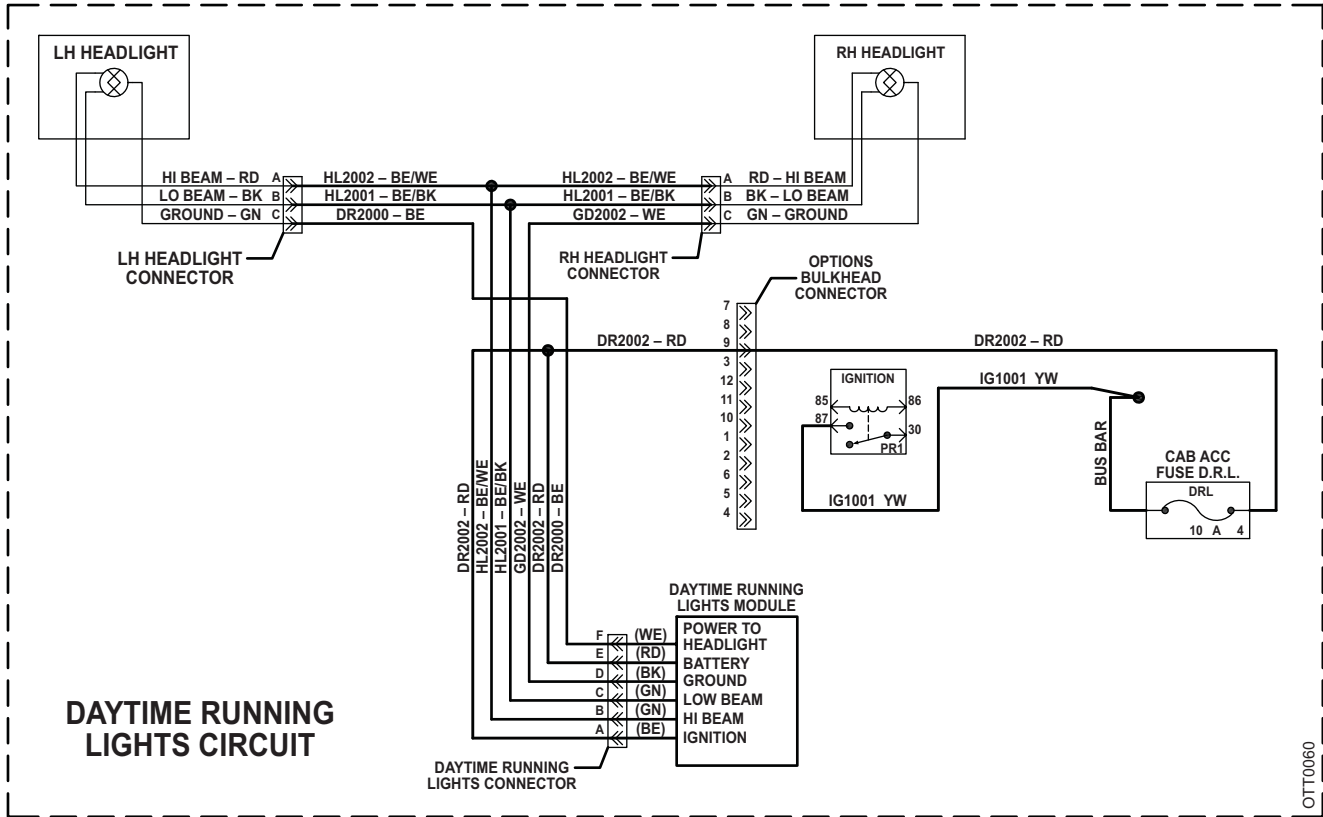

Daytime Running Lights Circuit

Components

- Daytime Running Lights Module
- Fuse — Daytime Running Lights (Cab Accessory Fuse Panel)
- Head Lamps
- Ignition Relay

Dome Light

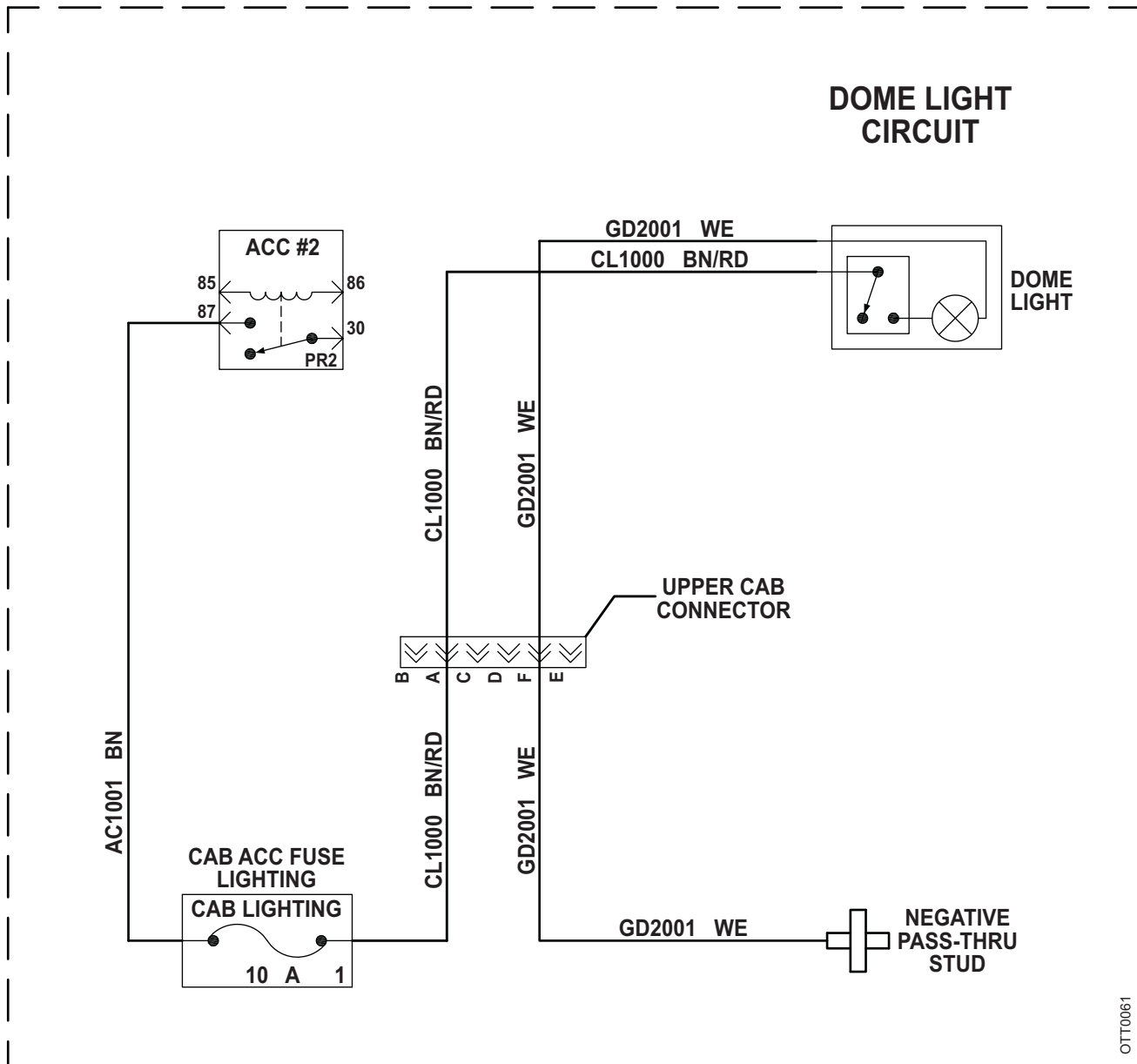

OTT0061

Dome Light Circuit

Components

Accessory Relay #2

Dome Lamp with Switch

Fuse — Cab Lighting (Cab Accessory Fuse Panel)

The lamp **On/Off** switch is on the dome light fixture.

Fifth-Wheel Control

Refer to *Transmission Shifter*.

Flood Light

Components

Accessory Relay #2

Flood Light

Flood Light Switch

Fuse — Exterior Lighting (Cab Accessory Fuse Panel)

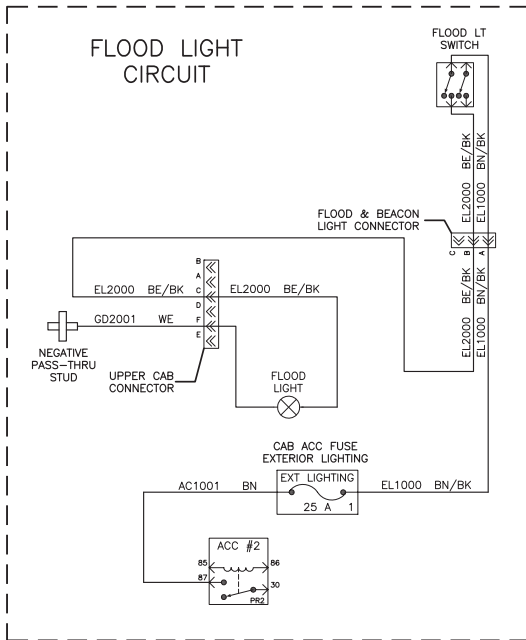

Flood Light Circuit

Headlights

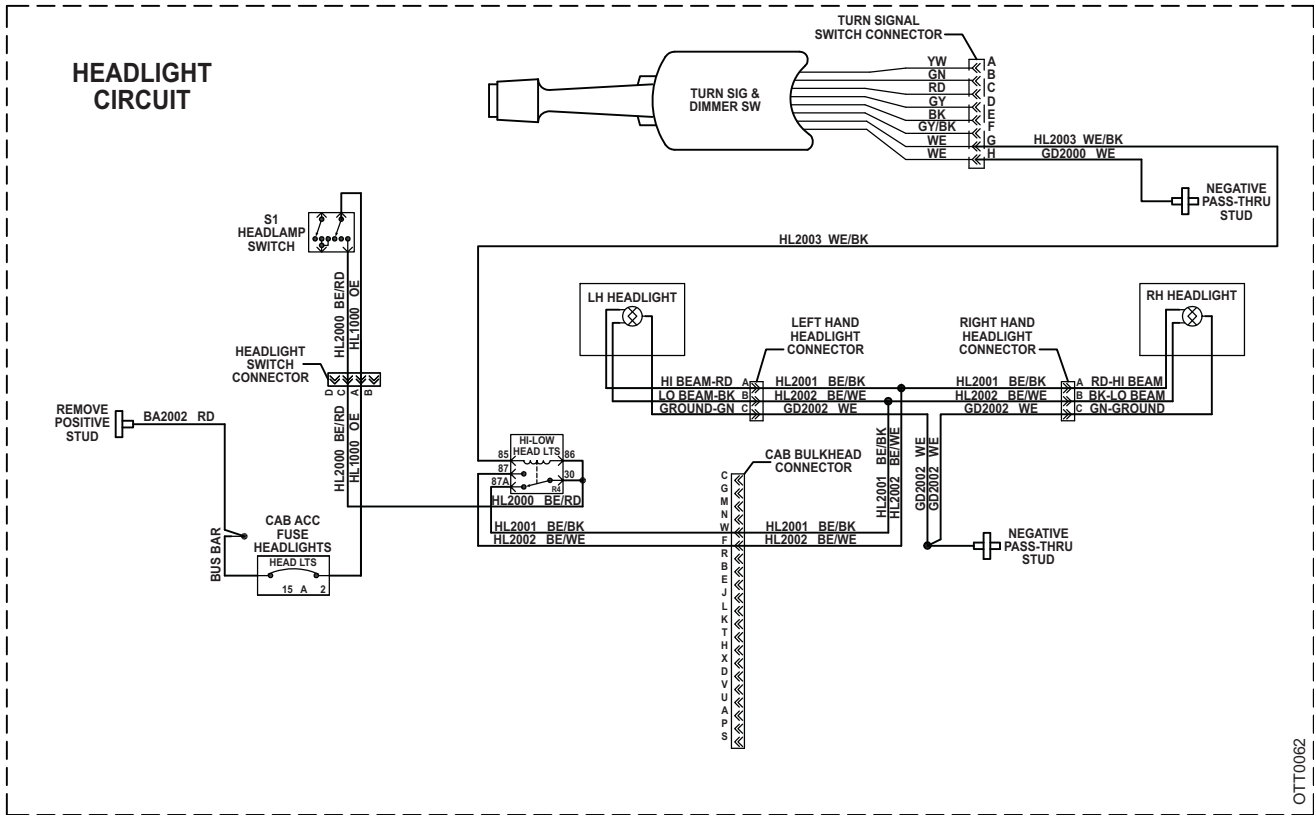

Headlight Circuit

Components

- Circuit Breaker — Head Lights (Cab Accessory Fuse Panel)
- Headlamps
- Headlight Relay (High/Low)
- Headlight Switch
- Turn Signal and Dimmer Switch

Marker Lights

Refer to *Clearance, Marker and Tail Lights*.

Panel Lighting

Refer to *Transmission Shifter*.

Strobe Light

Refer to *Beacon/Strobe Light*.

Tail Lights

Refer to *Turn Signal, Tail, Brake Lights and Emergency Flasher*.

Trailer Auxiliary Power

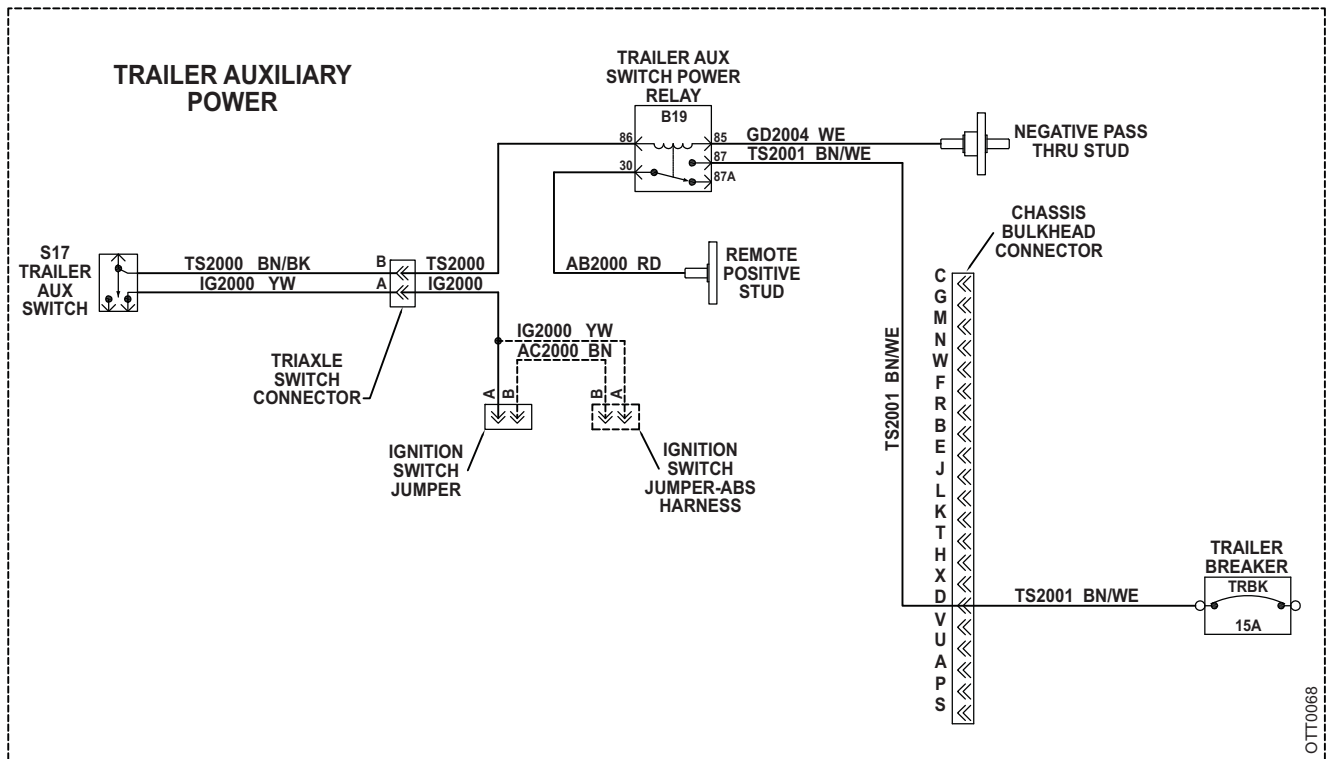

Trailer Auxiliary Power Circuit

Components

- Circuit Breaker — TRBK (Trailer Breaker)
- Ignition Switch Jumper
- Ignition Switch Jumper (ABS Harness)
- Relay — B19 (Trailer Auxiliary Switch Power Relay)
- Trailer Auxiliary Switch
- Triaxle Switch Connector

The trailer auxiliary switch is not used with ABS.

Transmission Shifter, Fifth-Wheel Control and Panel Lighting

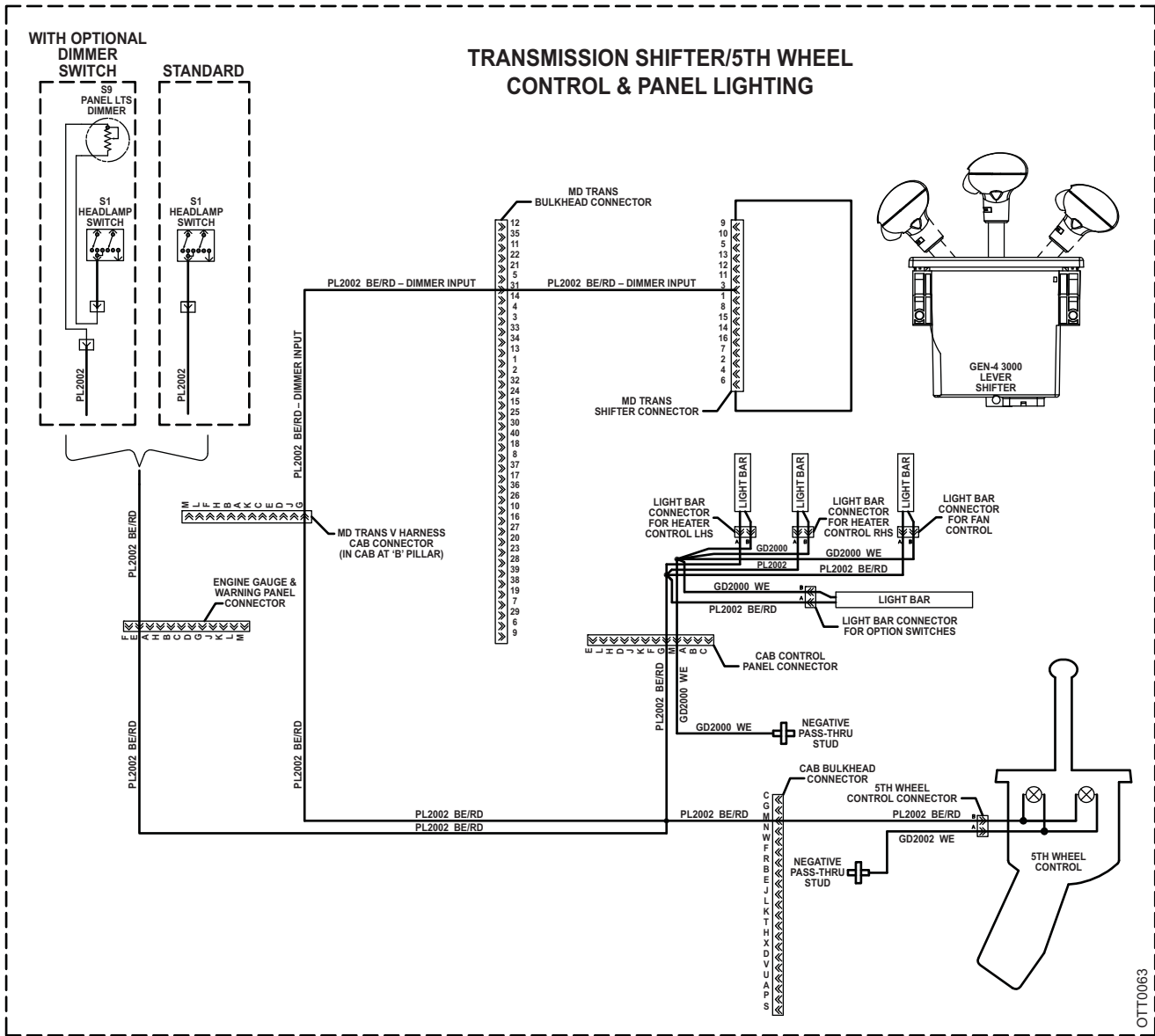

Transmission Shifter, Fifth-Wheel Control and Panel Lighting Circuit

Components

- Headlight Switch
- Lamps (2 — Fifth-Wheel Control)
- Light Bar — Heater Control LHS
- Light Bar — Heater Control RHS
- Light Bar — Fan Control
- Light Bar — Option Switches
- Panel Dimmer Switch (Optional)

The electroluminescent lamp illuminates when the ignition switch is in the **Run** position. It operates independently of the headlight switch.

Turn Signal, Tail, Brake Lights and Emergency Flasher

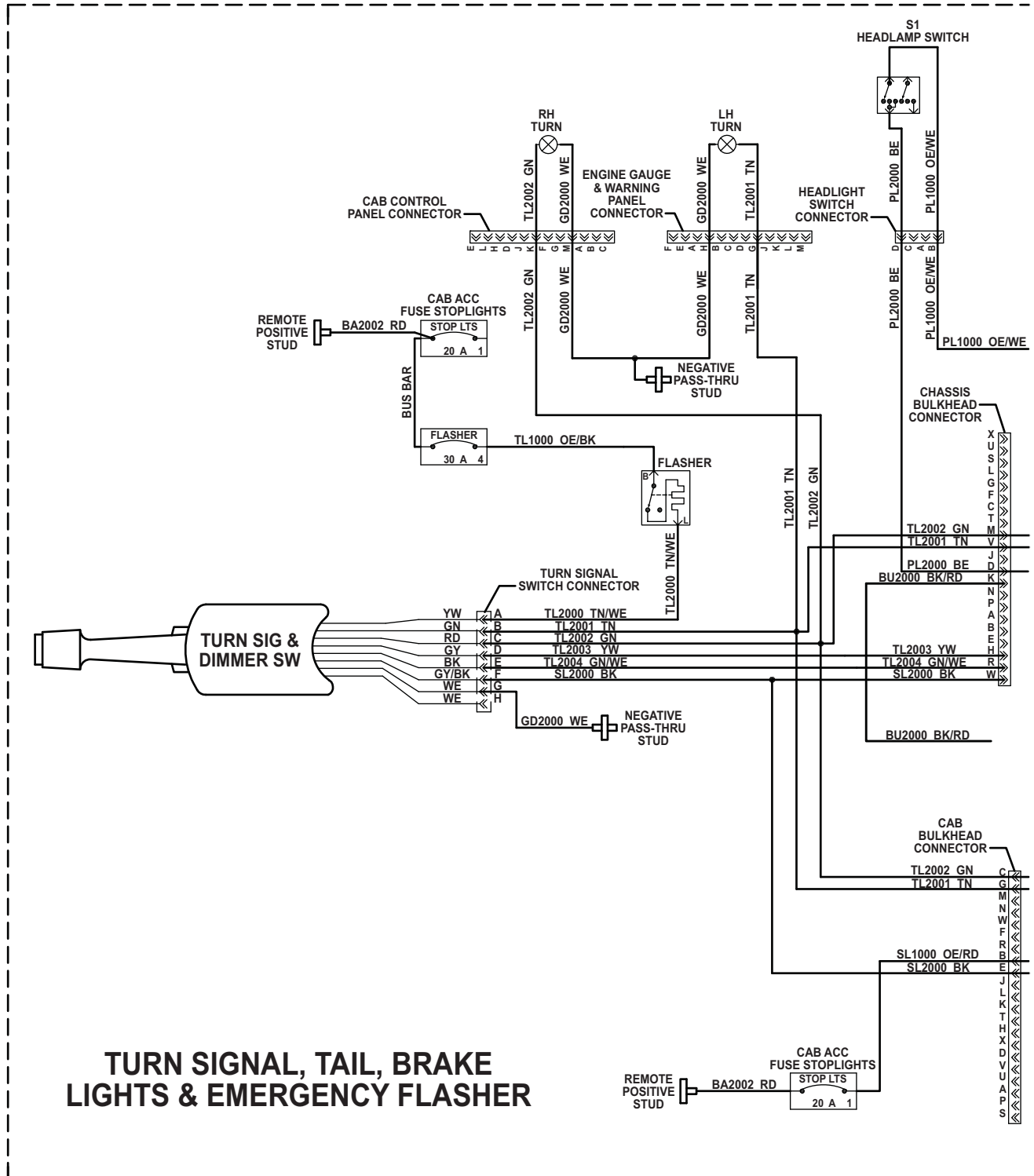

Turn Signal, Tail, Brake Lights and Emergency Flasher Circuit — Part A

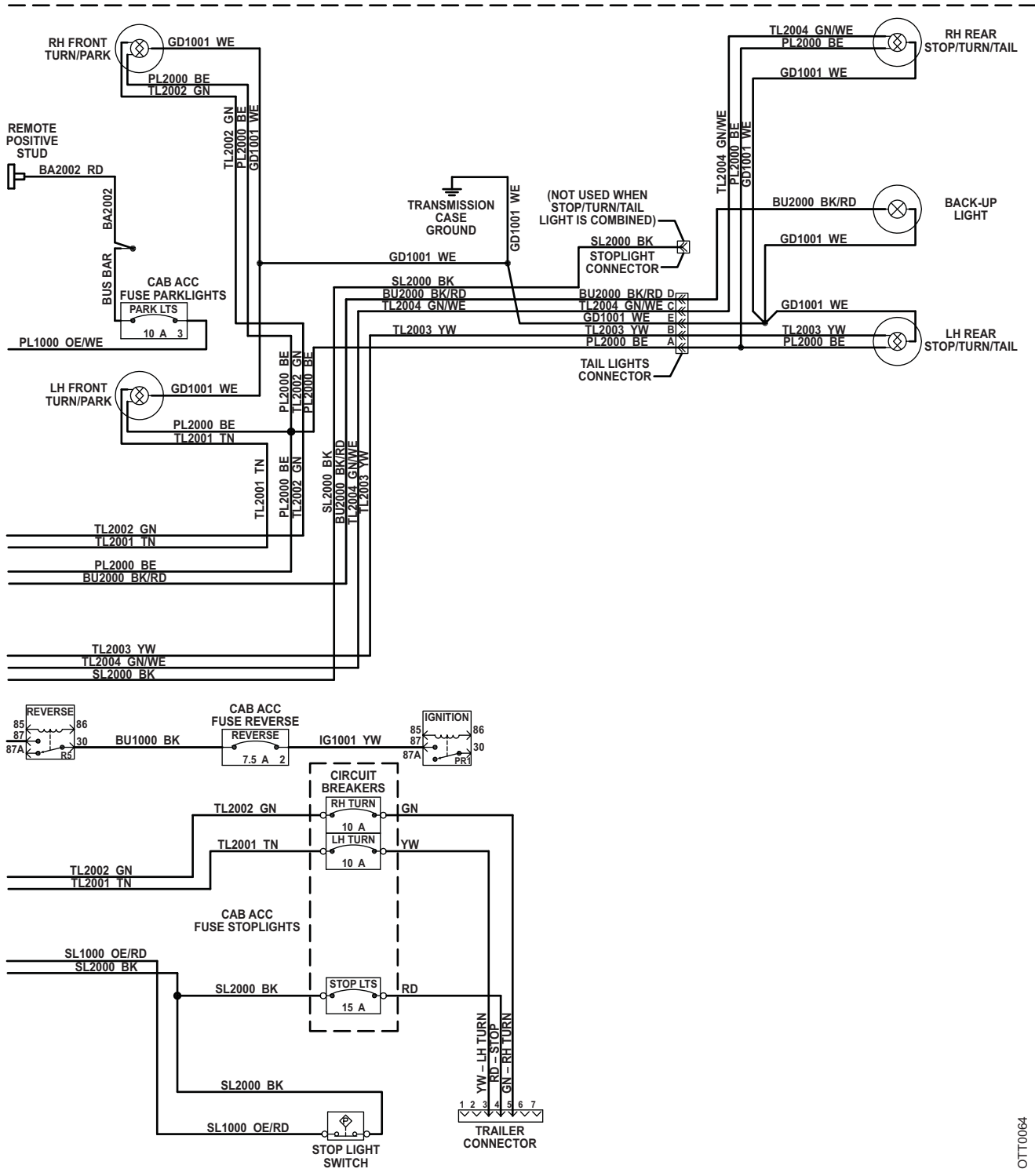

Turn Signal, Tail, Brake Lights and Emergency Flasher Circuit — Part B

Components

Backup Lamp

Circuit Breaker — Flasher (Cab Accessory Fuse Panel)

Circuit Breaker — Parking Lights (Cab Accessory Fuse Panel)

Circuit Breaker — Reverse (Cab Accessory Fuse Panel)

Circuit Breaker — Stop Lights (Cab Accessory Fuse Panel)

Circuit Breaker — Left Turn (Trailer Circuit Breakers)

Circuit Breaker — Right Turn (Trailer Circuit Breakers)

Circuit Breaker — Stop Lights (Trailer Circuit Breakers)

Flasher

Headlight Switch

Ignition Relay

Reverse Relay

Stop Light Switch

Stop/Turn/Tail Lamps (Right and Left)

Turn Signal and Headlight Dimmer Switch

Turn Indicator Lamps (Instrument Panel, Right and Left)

Turn Signal/Parking Lamps (Front, Right and Left)

Double-faced Turn/Marker Lights are standard equipment on vehicles manufactured to FMVSS and CMVSS specifications.

– F. Technical Data

0.1 Standard Vehicle Data

Ottawa Series Terminal Tractor

Standard features, dimensions and performance specifications are presented below for three typical chassis configurations. Optional equipment items are available including ABS braking systems and GCW ratings up to 125,000 pounds (56,700 kg) depending on the engine, transmission and axle combinations.

	Chassis Model and Configuration		
	Ottawa 4x2	Ottawa 4x2	Ottawa 6x4
Application (certification)	Off-Highway	DOT/EPA Certified	DOT/EPA Certified
Engine (standard)	Cummins QSB6.7	Cummins ISB07	Cummins ISB07
Peak power	160 HP at 2200 rpm (120 kW at 2200 rpm)	200 HP at 2300 rpm (150 kW at 2300 rpm)	200 HP at 2300 rpm (150 kW at 2300 rpm)
Torque	540 ft.lbs. at 1500 rpm (730 Nm at 1500 rpm)	520 ft.lbs. at 1600 rpm (700 Nm at 1600 rpm)	520 ft.lbs. at 1600 rpm (700 Nm at 1600 rpm)
Transmission (standard)	Allison 3000RDS	Allison 3000RDS	Allison 3000RDS
Gearing	3 Forward, 1 Reverse	4 Forward, 1 Reverse	4 Forward, 1 Reverse
Propeller shaft	Spicer 1710	Spicer 1710	Spicer 1710
Axle, front	Meritor FF961	Meritor FF961	Meritor FF961
Axle(s), rear	Meritor RS-23-186	Meritor RS-24-160	Meritor RT-40-145
Brake system	Air	Air with ABS	Air with ABS
Wheel ends:			
Front – type, size	S-cam, 16.5x5 inch (419x127 mm)	S-cam, 16.5x5 inch (419x127 mm)	S-cam, 16.5x5 inch (419x127 mm)
Rear – type, size	S-cam, 16.5x7 inch (419x178 mm)	S-cam, 16.5x7 inch (419x178 mm)	S-cam, 16.5x7 inch (419x178 mm)
Slack adjusters	Manual	Automatic	Automatic
Air compressor	Wabco, 15.2 cfm (0.43 m ³ /minute)	Wabco, 15.2 cfm (0.43 m ³ /minute)	Wabco, 15.2 cfm (0.43 m ³ /minute)
Air reservoirs	3,582 cu.inch (2 tanks) (58.7 liter)	5,688 cu.inch (3 tanks) (93.2 liter)	5,688 cu.inch (3 tanks) (93.2 liter)
Tires	11R 22.5, 14PR	11R 22.5, 14PR	11R 22.5, 14PR

	Chassis Model and Configuration		
	Ottawa 4x2	Ottawa 4x2	Ottawa 6x4
GAWR Front Rear	12,000 lbs. (5,443 kg) 23,000 lbs. (10,443 kg)	12,000 lbs. (5,443 kg) 24,000 lbs. (10,886 kg)	12,000 lbs. (5,443 kg) 40,000 lbs. (18144 kg)
GCWR	96,000 lbs. (43,545 kg)	80,000 lbs. (36,287 kg)	80,000 lbs. (36,287 kg)
Wheelbase	110 inch (2,794 mm)	110 inch (2,794 mm)	146 inch (3,708 mm)
Length overall	181 inch (4,597 mm)	181 inch (4,597 mm)	244 inch (6,198 mm)
Width overall	97 inch (2,464 mm)	97 inch (2,464 mm)	97 inch (2,464 mm)
Turning radius	17 ft. (5.2 m)	17 ft. (5.2 m)	19.85 ft. (6.1 m)
Fifth-wheel boom lift capacity	60,000 lbs. (27,216 kg)	60,000 lbs. (27,216 kg)	60,000 lbs. (27,216 kg)
Fifth wheel	FW 3500	FW 3500	FW 3500
Chassis weight	14,500 lbs. (6,577 kg)	14,500 lbs. (6,577 kg)	18,000 lbs. (8,165 kg)

0.2 Hydraulic System

Ottawa Series 4x2 and 6x4

The hydraulic system includes three sub-systems.

- Fifth-wheel boom
- Power steering
- Cab tilt

All three draw and use fluid from a common 16-gallon reservoir. Specifications for the individual sub-systems follow.

Boom System Components	Specification
Boom drift down (maximum, 5-inch (127 mm) cylinder)	3 inches (76 mm) per hour
Hydraulic fluid	Dexron® III
Pump flow (standard system)	10 gallons (37.5 liter) per minute at 1200 rpm
System capacity:	
Tank only	16 gallons (60.5 liter)
System	21 gallons (79.5 liter) (approximate)
System relief pressure	2000 psi (138 bar)

Power Steering System Components	Specification
Pump flow (minimum)	4 gallons (15.1 liter) per minute at 1200 rpm
Pump relief setting	2100 psi (145 bar)

Cab Tilt System Components	Specification
Pump flow (minimum)	0.3 gallons (1.1 liter) per minute at 1200 rpm
Pump relief setting	3200 psi (159 bar)

0.3 Fluids, Lubricants and Sealants

Ottawa Series 4x2 and 6x4

Following are the specified fluids, lubricants and sealants by component. These are to be used in accordance with the recommended maintenance schedule.

Component	Sealant or Lubricant
Axle, rear	EP 85-140 (Also, refer to axle manufacturer's specifications.)
Cab: Cab pivot bearings Cab tilt release mechanism Door striker bolts Seat adjuster slides	Lubriplate® or equivalent (semi-fluid grease having extreme pressure properties and containing zinc oxide)
Cab: Door hinges Rear door rollers	Silicone spray
Chassis: Boom pivot (at frame) Brake cam pivots Brake slack adjusters Fifth-wheel pivot pins Fifth-wheel top plate Fifth-wheel jaws Front axle king pins Hydraulic cylinder bearings Otto-Ride pivots Propeller shaft splines and universal joints Speedometer adapter Spring shackle pins	Lithium Grease #1
Engine: Oil Coolant, anti-freeze	SAE 15W-40 50/50 Ethylene-Glycol/Water (Also, refer to engine manufacturer's specifications.)
Hydraulic system fluid	Dexron® III
Steering fluid (power steering)	Dexron® III (from hydraulic system)

Component	Sealant or Lubricant
Steering linkage (slip joint, knuckles, tie rod and drag link ends)	Lithium grease (warm weather) NLGI 0 lubricant (cold weather)
Transmission fluid/lubricant (automatic)	Transynd TES-295 Approved (Also, refer to transmission manufacturer's specifications.)
Wheel bearings, front axle: Grease lubricated Oil lubricated	NLGI 1 or 2 EPA 85-140 (Also, refer to axle manufacturer's specifications.)

0.4 Fastener Torque Values

Ottawa Series 4x2 and 6x4

Following are the specified torque values required for scheduled maintenance operations and typical repair and/or adjustment procedures covered in this manual.

Component	Specified Torque Value	
Axle mounting:		
Front axle clamp plate bolts	210 ft. lbs.	285 Nm
Rear axle clamp plate bolts:		
Bolt head	600 ft. lbs.	813 Nm
Nut	400 ft. lbs.	542 Nm
Rear axle torque link bolts	380 ft. lbs.	515 Nm
Cab latch mounting bolts	65 ft. lbs.	88 Nm
Cab latch bar plate mounting bolts	65 ft. lbs.	88 Nm
Cab pivot pin retainer screws	35 ft. lbs.	47 Nm
Cab rear door roller capscrews	75 in. lbs.	8.5 Nm
Cab suspension:		
Assembly mounting bolts	220 ft. lbs.	298 Nm
Shock absorber mounting bolts	100 ft. lbs.	136 Nm
Cab tilt cylinder mounting bolts	200 ft. lbs.	271 Nm
Cab tilt pump mounting bolts	35 ft. lbs.	47 Nm
Cab tilt pump relief valve adjusting screw jam nut	80 in. lbs.	9.0 Nm
Boom cylinder mounting:		
Upper mount bolts	55 ft. lbs.	75 Nm
Lower mount bolts	55 ft. lbs.	75 Nm
Lower mount cross-bar locknuts	600 ft. lbs.	813 Nm
Boom pivot cross-bar locknuts	600 ft. lbs.	813 Nm
Boom pump mounting bolts	55 ft. lbs.	75 Nm
Boom pump relief valve adjusting screw jam nut	15 ft. lbs.	20 Nm
Spring pin bolts, fixed/shackle (front axle)	150 ft. lbs.	203 Nm
Steering gear mounting bolts	350 ft. lbs.	475 Nm
Wheel lug nuts	450-500 ft. lbs.	610-678 Nm

– G. Appendixes

Description

This section is not applicable for this vehicle.

